



Si3452MS8 EVALUATION BOARD USER'S GUIDE

1. Introduction

The Si3452MS8 8-port evaluation kit (Si3452MS8-KIT) is intended for Power over Ethernet (PoE) Power Sourcing Equipment (PSE) system designers interested in evaluating the Quad-port Si3452 PSE controller. While evaluation kits are normally shipped with Si3452 devices that use Silicon Laboratories' proprietary dV/dt™ disconnect, they can also be used for evaluation of the pin-compatible Si3453, which uses dc disconnect. In this case, the Si3452 devices must be replaced with the appropriate Si3453 device. Please refer to "8. Ordering Guide" on page 38 for more information.

The Si3452 is controlled through an I²C (or SMBus) interface. For convenience in evaluation, a graphical user interface (GUI) is provided, giving an easy-to-use visual display and control of the Si3452 I²C registers. The evaluation kit assumes the user has access to a PC to control the evaluation board with the provided GUI.

The user is also responsible for providing an appropriate high-voltage power supply. The power supply should be 45 to 57 V for normal PoE or 51 to 57 V for PoE+. The Si3452 can supply over 30 W to each port. Thus, the two Si3452 controllers for the eight port demo system can provide over 240 W of total power. Normally, a 50 to 100 W power supply is used. While the classification and actual current consumption of each port is available, the demo GUI does not implement system-level power management. Contact Silicon Laboratories for more information about system-level power management options.

The Si3452MS8 kit has been thoroughly tested for standards compliance and interoperability. Contact Silicon Laboratories for test reports using Sifos PoE test equipment and University of New Hampshire PoE standards compliance and interoperability reports.

Si3452MS8-KIT

2. Kit Contents

This user's guide includes instructions on the use of the Si3452 register control GUI. An optional Power Manager GUI is described in the Si3452 Power Manager GUI user's guide on the CD-ROM. The installation instructions for the hardware and USB to I²C driver in this user's guide must be followed before installing and using the Si3452 Power Manager GUI.

Table 1. Evaluation Kit Contents

Kit	Contents
Si3452MS8-EVB r1.1	The Si3452 8-port evaluation board with connector for an external 50 V power supply. The power supply must be capable of supplying the required amount of power for all PoE loads being connected. Standard boards are populated with Si3452-B01-GM parts.
Si3452CB-EVB r1.1	An RJ-45 connector board configured as power over Ethernet Gigabit mid-span injector.
	A 24-wire cable to connect the Si3452 evaluation board to the mid-span injector board
USB-SMBus-EB3	A USB to I ² C (or SMBus) evaluation board. This board is preconfigured with updated firmware to support I ² C transactions.
	A wire for connecting the USB to SMBus power pin to the isolator of the Si3452 evaluation board.
	A USB cable to connect to a host PC
Si3402ISO-EVB	A PD evaluation board configured to provide a Class 3 signature.
Si3402ISO-C4-EVB	A PD evaluation board configured to provide a Class 4 signature.
	10 Ω loads for the evaluation boards. Each load will consume 2.5 W, which is about 3 W referred to the PSE side.
	Two Ethernet cables to connect the Si3400 and Si3401 evaluation boards to the connector board.
CD-ROM	Software drivers for the USB to SMBus adapter and a GUI for the Si3452 registers on a CD-ROM. Applicable applications notes and data sheets are also included.

3. Software Installation

The software supplied with this kit requires a Windows™ based PC running Windows Vista, Windows 7, or Windows XP. There are no known compatibility issues.

The Si3452 evaluation kit includes a USB to SMBus adapter, which needs a windows driver to function properly. Once the driver is installed, the GUI itself must be installed. Follow these steps for driver and GUI installation. Uninstall instructions are provided in the appendix of this document.

3.1. USB to I²C Driver Installation

From the supplied disk, run the USB SMBus Setup.exe in the “Software” directory of the CD ROM. After installation is complete, plug the USB to SMBus adapter into any USB port. A New Hardware wizard will appear and ask whether Windows can connect to Windows Update to search for software. Select “No, not this time”, and click “Next”.



Figure 1. New Hardware Wizard Screen

Select “Install the software automatically (Recommended)”, and click “Next” to continue.

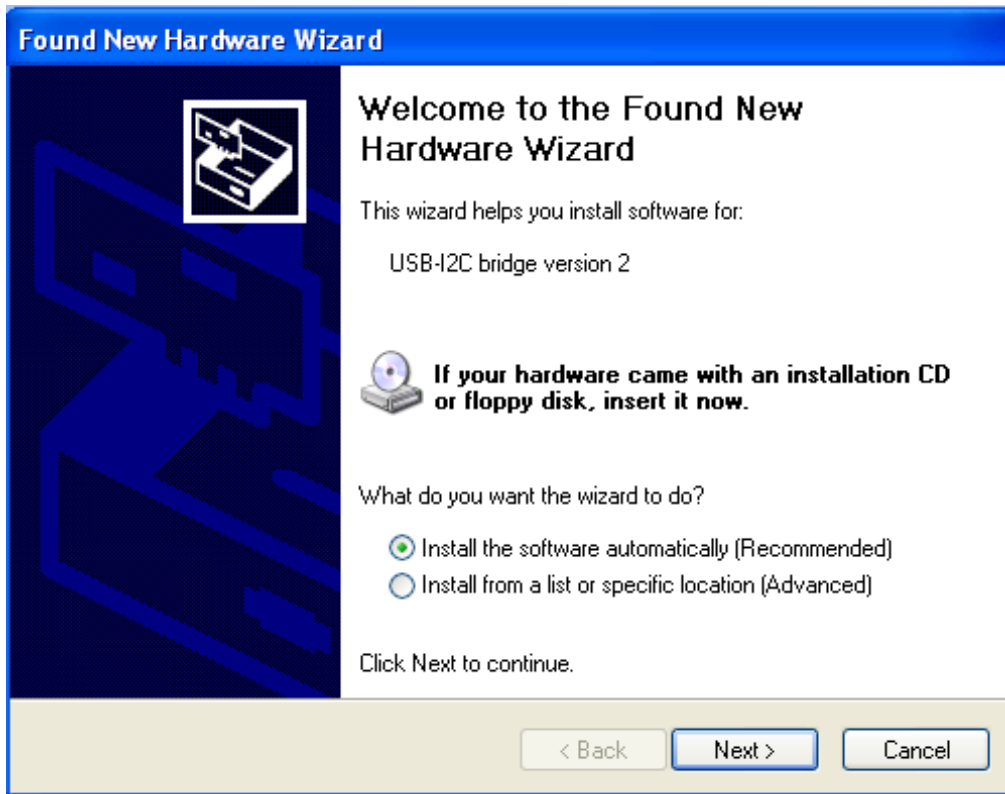

Figure 2. Choose “Install The Software Automatically”

After successfully finishing the driver installation, the yellow LED on the USB-I2C board will turn on.

3.2. Si3452 Monitor GUI Installation

Right-click on “Si3452_I2C_Monitor_Setup.exe” in the “Software” directory of the CD ROM, and select “Run as administrator”. Accept the EVLA. It will start to install PC GUI (Si3452 I2C Monitor). Press “Next” to continue.

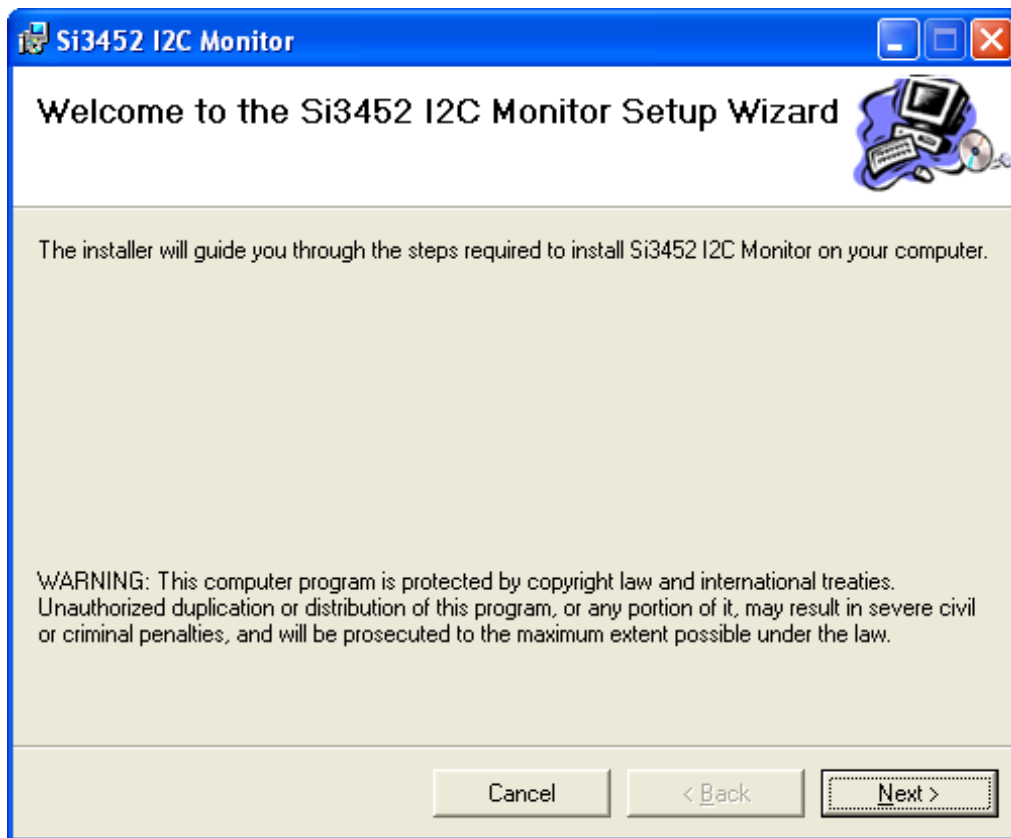

Figure 3. I²C Monitor Setup Wizard

Si3452MS8-KIT

Select the folder path where to install the GUI (the default location is recommended) and press “Next”.

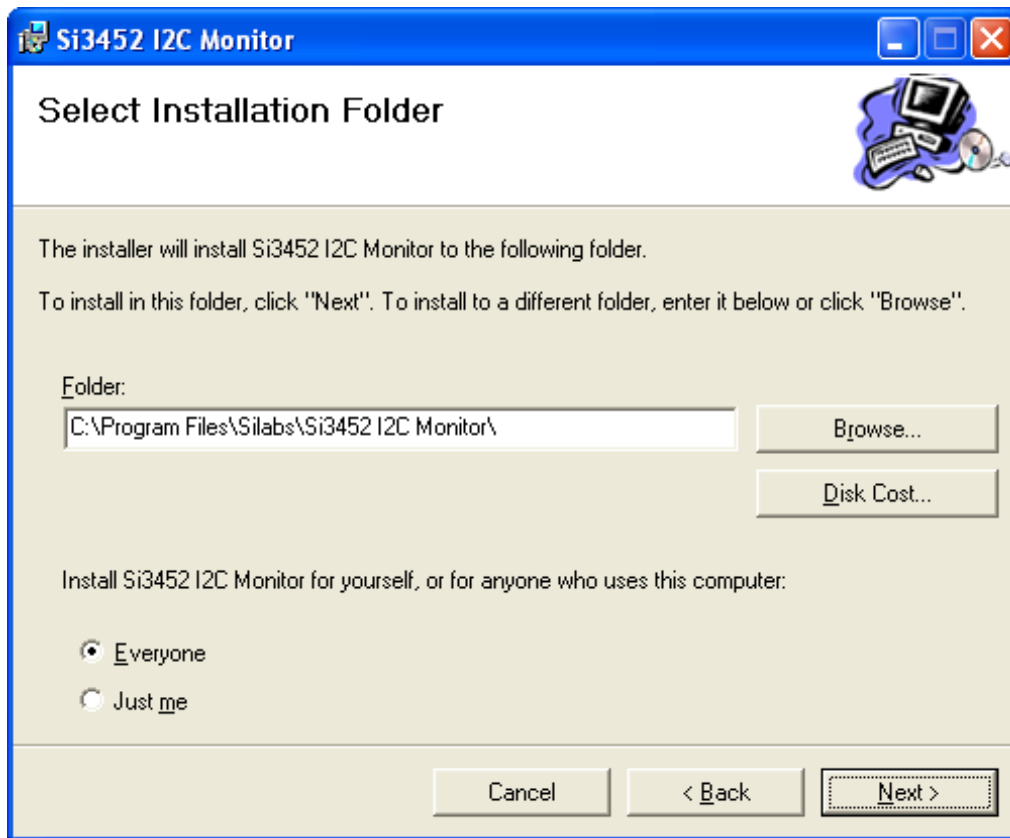

Figure 4. I²C Monitor Installation Folder Screen

After successful installation, the program can be run from the installation directory or from the Start menu (Start→All Programs→Silicon Laboratories→Si3452 I2C Monitor).

4. Hardware installation

Figures 5 and 6 show how all the hardware pieces of the Si3452 evaluation board fit together.

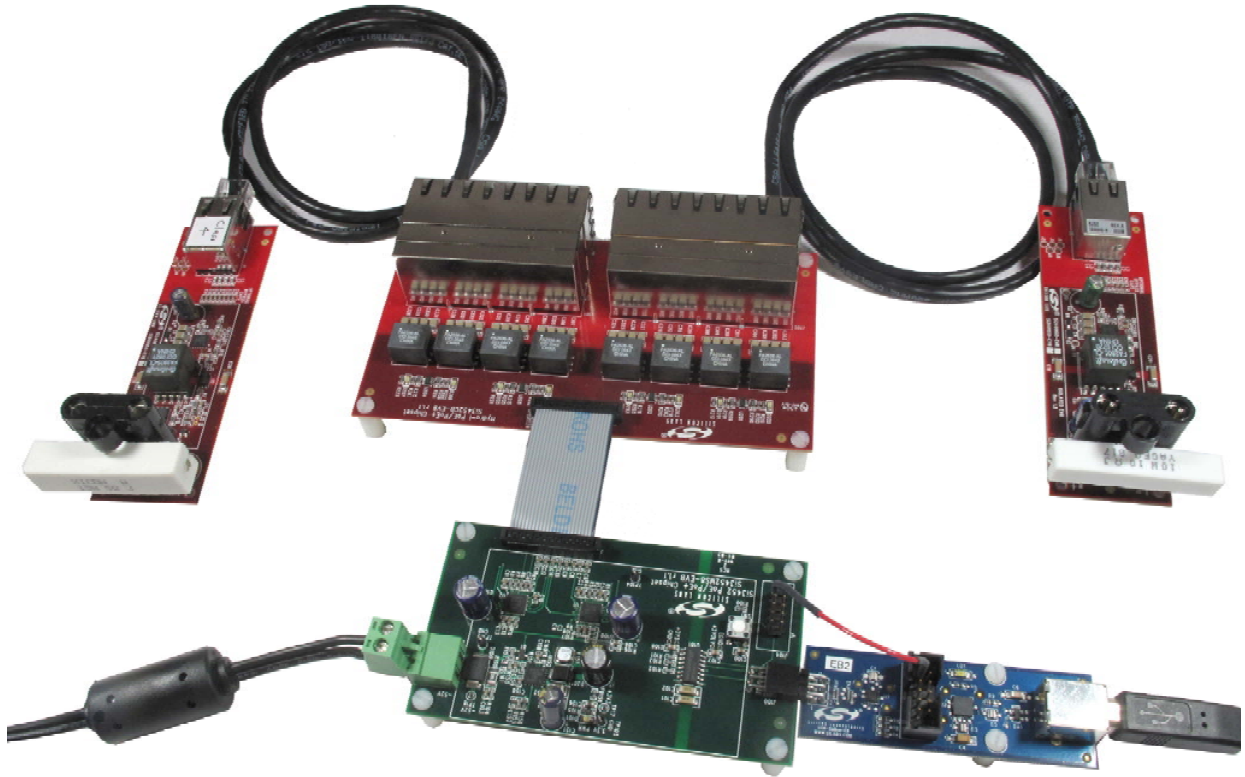

Figure 5. Evaluation Board Hardware

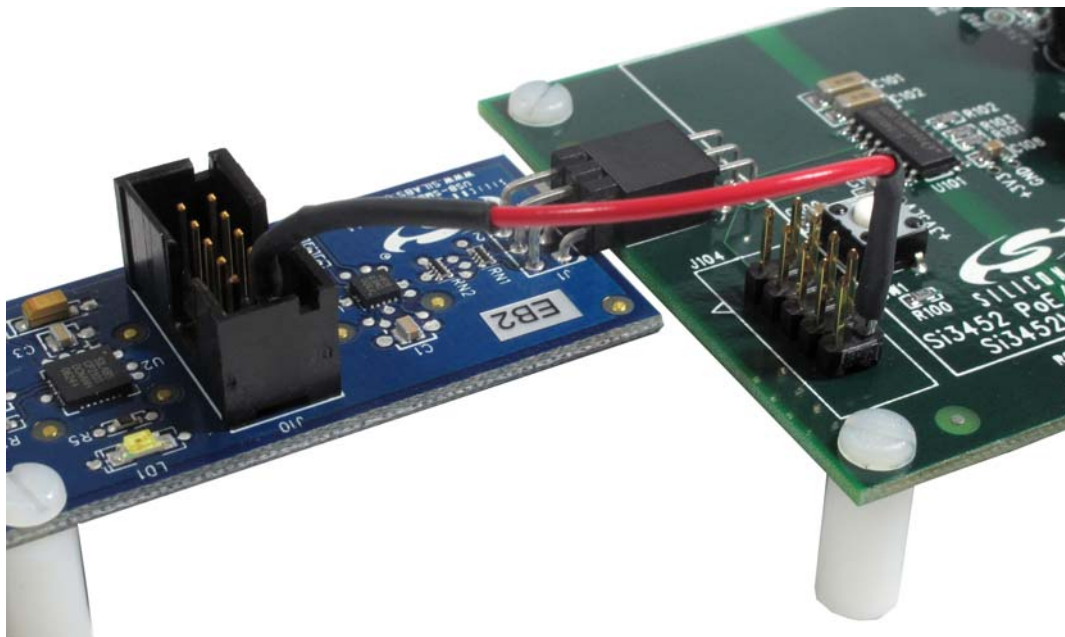

Figure 6. Connection to Supply Power to the Isolated Side from the USB Adapter

Si3452MS8-KIT

Perform the following steps:

1. Connect the Si3452 evaluation card (Si3452MB8-EVB) to the RJ45 (Si3452C3-EVB) card using the 24-pin ribbon cable.
2. The power should be applied before the USB-SMBus adapter is plugged in. The high-voltage power supply should be connected to the evaluation system before it is plugged into the ac mains. Hot insertion of the high voltage is not recommended. Be careful about the polarity of the high-voltage power supply. After the high voltage supply is turned on, the power LED D101 will glow, indicating that the 3.3 V supply is active.

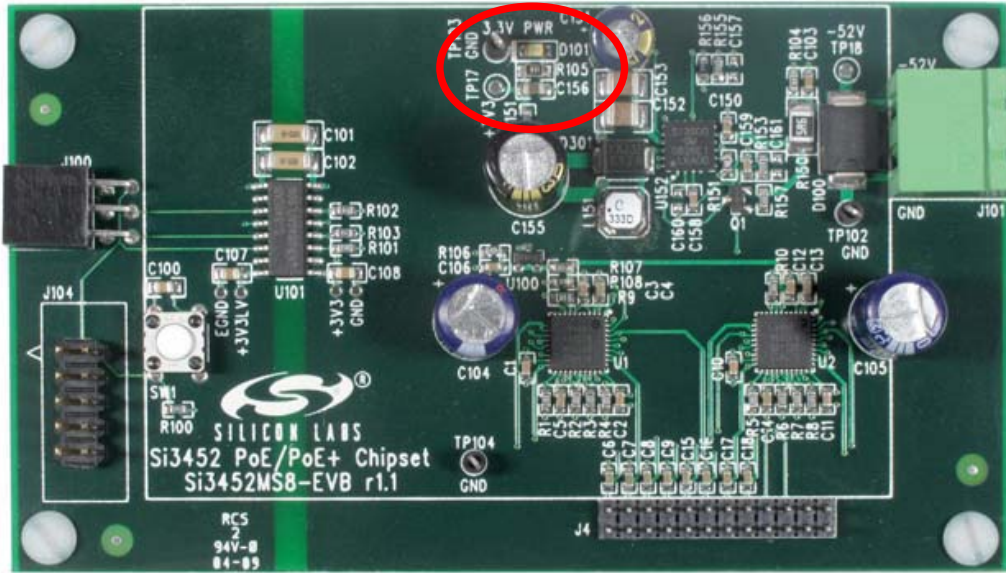

Figure 7. Location of D101 which Indicated Power Has Been Properly Applied

3. If not already done during the software installation step, plug the USB to SMBus adapter into the computer USB cable. Connect the USB side before connecting the SMBus side. If the drivers were installed properly, the PC should recognize the adapter.
4. Plug the USB-SMBus adapter into the Si3452 MS8-EVB.
5. Connect power to the isolated side of the Si3452. A convenient way to do this is to use the supplied wire, and connect the 3.3 V power derived from the USB port to the isolator. This wire connects pin 10 of J104 on the Si3452 evaluation board (3.3 V in) to pin 1 of J10 on the USB to SMBus adapter.
6. Plug in powered devices. The evaluation board is configured as a midspan power injector. The data input lines are on the top row, and the power plus data output lines are on the bottom row.

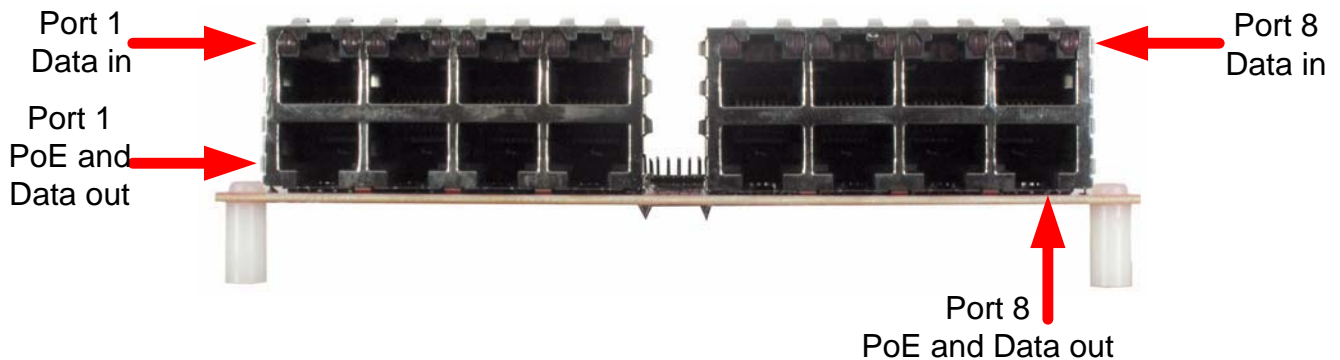

Figure 8. Connector Board Configuration

7. Start the PC GUI.

5. Using the GUI

The GUI is simply a graphical representation of the I²C registers as described in the Si3452 data sheet. Normally, the registers are polled, but the polling is not required. If there is no polling, the register contents can be read one time by the refresh button. If desired, the actual binary content of the registers can be observed in the left hand portion of the GUI. Also, individual register reads and writes are possible.

When the GUI is first started, the screen will look like the one shown in Figure 9.

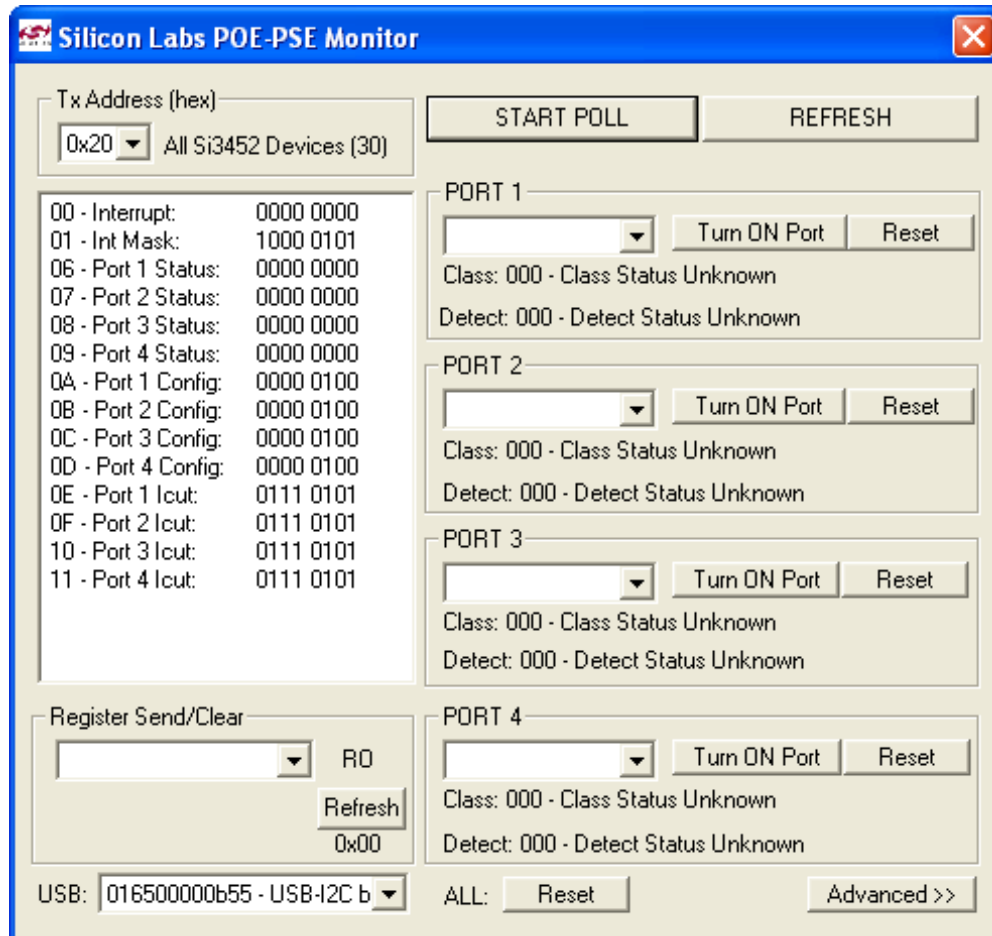

Figure 9. GUI Start-Up Screen

Pressing "Start Poll" and "Advanced" should yield a screen like the one shown in Figure 10.

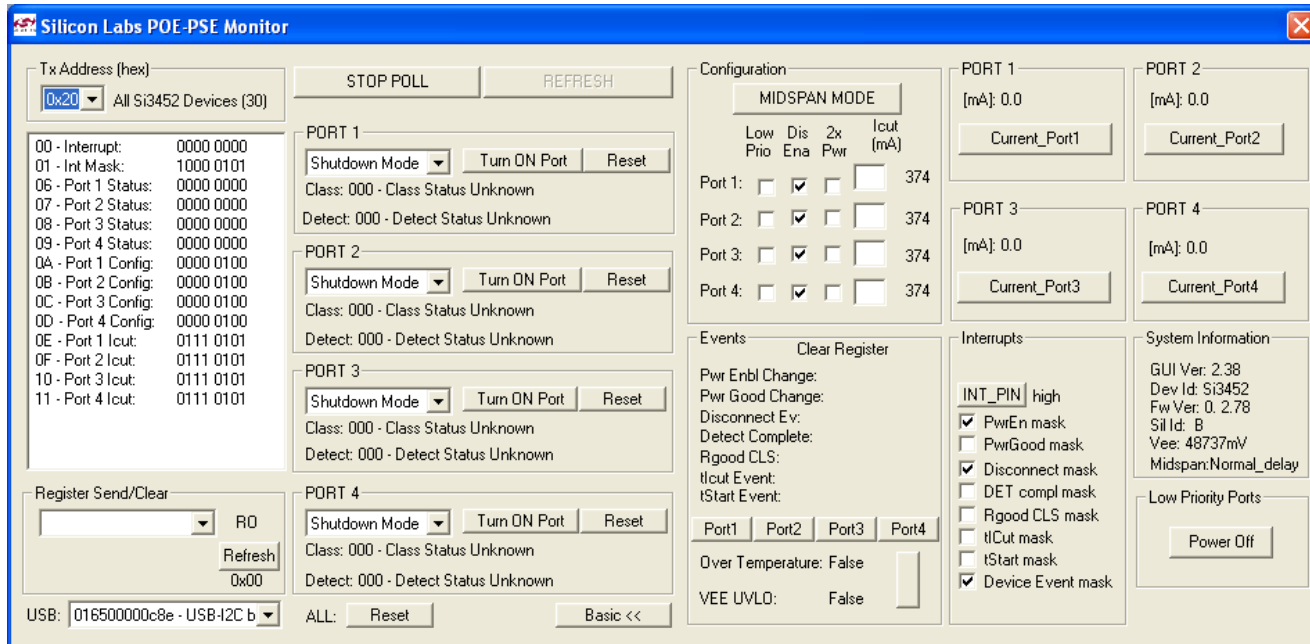

Figure 10. GUI Screen after Clicking “Advanced” and “Start Poll”

If the power-up order was not followed, it is possible that the Si3452 will not be recognized, in which case the firmware revision and Vee will show as 0.0.0 and 0 mV. In this case, close the GUI using the task manager if required; unplug the power and USB to SMBus adapter; re-apply the power in the above sequence, and restart the GUI.

To avoid the possibility of I²C bus lockups, the GUI polling should be stopped before the power is removed. If this is not done, it may be necessary to use the task manager to stop the GUI.

From this point, the Si3452 can be controlled. The Si3452 devices are wired to addresses 0x20 and 0x21. The devices also respond to the broadcast address (0x30).

5.1. Detailed GUI Description

Normally, the broadcast address is not used; so, set the I²C transmit address to 0x20 or 0x21. In the screen shot in Figure 11, all ports of the Si3452 at address 0x20 have been put in auto mode. The letters in red do not appear; they are references for the detailed description.

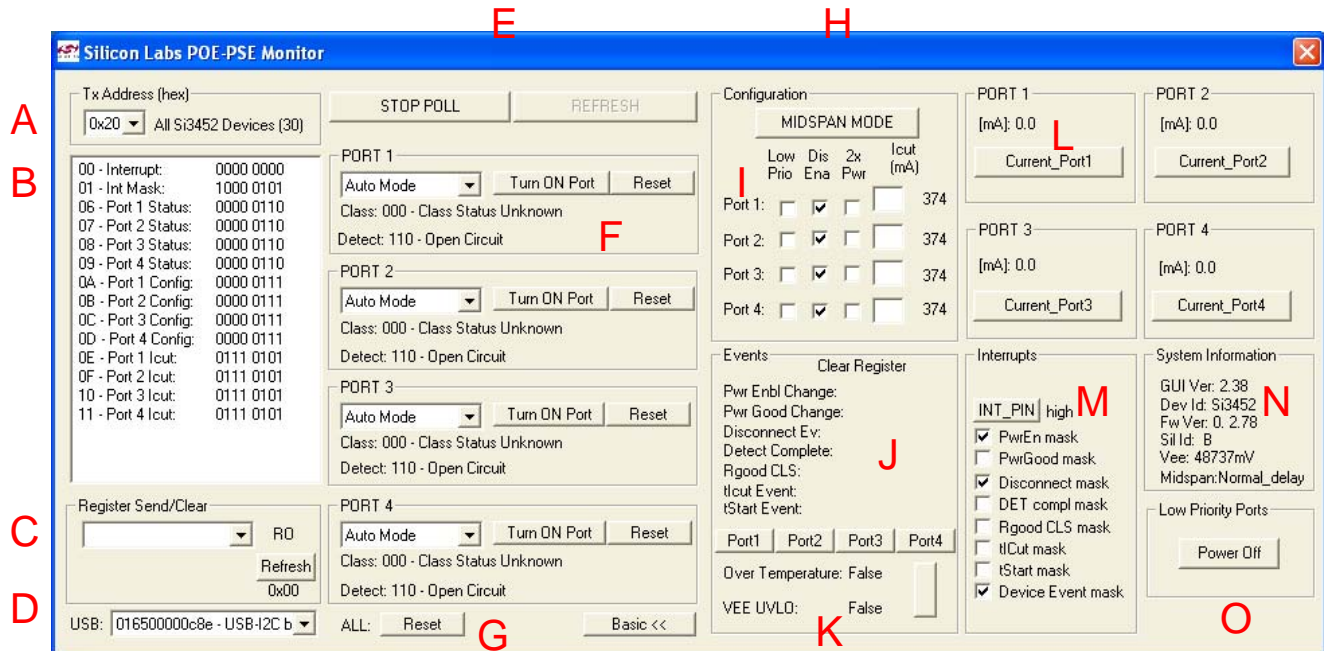

Figure 11. GUI Screen Description Guide

- The transmit address drop-down menu is used to set the I²C address that the GUI uses to communicate with the Si3452 devices. For the Si3452MS8 kit, these addresses are 0x20 and 0x21. The GUI supports all 12 valid I²C address settings of the Si3452.
- This pane displays registers 0x00 through 0x11 of the selected Si3452 device. The contents of these registers are also displayed in other GUI panes in an easier-to-read format.
- This pane allows reading or writing any register of the Si3452 using hexadecimal. This can also be done using other GUI panes.
- This pane shows the USB-SMBus adapter information. If no adapter information is displayed, the driver was not installed properly and probably needs to be re-installed.
- The GUI can work in “polling” mode where the registers (other than “clear on read” and “write only”) are polled continuously. If the GUI is not in polling mode, clicking the “refresh” button reads these registers once.
- These panes show the status and basic configuration of each port and allow basic port control.

Si3452MS8-KIT

GUI Display	Description
Detect	The lower three bits of the port status registers are the detection status bits. These bits are decoded and displayed as the detect status. Detection status indicates the result of powered device (PD) detection. If a detection has not been done, the result is “unknown”. Other possible results are “short circuit”, “resistance too low”, “valid or good detection result”, “resistance too high”, or “open circuit”.
Class	The next three bits are classification status. If a classification has not been done, the result is “unknown”; otherwise, the PD classification is shown (class 0 – 4); this is displayed if there was an error due to overload or unequal events for the PoE+ two-event classification.
Mode drop down menu	The lower two bits of the port mode register can be set by the drop-down menu. The possible modes are “shutdown” (port cannot be turned on), “manual” (port can be turned on by sending a turn on command), “semi-auto” (detection is performed, and, if the result is “good”, classification is performed; the port can be turned on by sending a turn on command), and “auto” (detection, classification, and port turn-on are all automatic).
Turn on or Turn off	Depending on whether the port is on or off (as determined by the Penable bit 6 of the port status register), the turn on port or turn off port command button is presented. Clicking this button results in the appropriate command being written to register 0x12.

- G. Clicking the reset button results in the reset command being written to register 0x12. This results in a complete reset of the Si3452 that is being addressed.
- H. Clicking the Midspan mode button results in sending the command to register 0x12 that toggled the detection back-off delay time from end point mode to mid-span mode.
- I. The boxes in this pane set the more advanced port configuration bits in the port configuration registers. A port that is “low priority” will be turned off when the “turn off low priority ports” is written. Normally, when the PD is removed, it will be disconnected; but, if the disconnect enable bit is not checked, the port will stay on until forced off by a command. 2x power mode doubles the port current limiting to approximately 850 mA and enables 2-event classification. If I_{cut} is exceeded for 60 ms, the port will also be turned off. In auto mode, I_{cut} is set according to the port classification and 2x power mode, but it can be changed dynamically.
- J. This pane displays the event register information. The port event registers are clear on read; so, clicking the read button displays the contents and then clears the register.
- K. The device status register read in this pane. The device status register is not clear on read; but, when it is read, this clears bits 5 and 6 of the interrupt register if they are set. The device status register is polled; so, in polling mode, device status events only generate a momentary interrupt.
- L. These panes display the contents of the port current registers. These registers are 2 bytes; so, to make sure the bytes are synchronized, there is a command that is sent to Register x012 to read the current. The read current command is sent by clicking the button in this pane. In polling mode, the current is read and updated as part of the polling process.
- M. The interrupt pin status and interrupt pin mask are displayed in this pane. The USB to SMBus adapter does not continuously monitor the interrupt pin; so, there is some delay between pin transitions and display of the pin status on the GUI.
- N. The Si3452 revision registers and Vee information is displayed in this pane. Vee is a 2-byte register; so, Vee is read by issuing a command in polling mode. Since the GUI does not have a button for issuing the read Vee command, click the “Refresh” button in pane E to update the Vee information.
- O. The button in this pane issues the “turn off low priority ports” command. This command is always sent to the broadcast address (0x30); so, clicking this button results in all low-priority ports on both devices being turned off.

6. Operating the System

The RJ45 connector board has 8 LEDs for the 8 ports. The LEDs are driven by a comparator circuit with a threshold of about 2 V. When the ports are in auto mode, the LEDs in the RJ45 connector board will flash, indicating the detection cycle until a valid PD is connected. Once a valid PD is connected and the port is turned on, the LEDs will glow steadily until the PD is disconnected. Once the PD is connected, the port current will be displayed on the GUI.

The easiest way to get started is to put all of the ports in Auto mode. In Auto mode, detection, classification, power management based on classification (Icut setting), disconnect (when enabled by “Dis Enable”), fault protection, fault recovery, and port monitoring all happen without user intervention.

If the GUI is left in polling mode, the port status, port current, Vee voltage are all automatically updated by polling the appropriate registers of the Si3452.

The Si3452 itself normally powers up as Alternative A, which means there is no detection back-off. This is the most common usage for the Si3452. The RJ-45 connector board for the evaluation kit is configured to inject the power on the “spare pairs” of the Ethernet cable, which is the Alternative B or “Midspan” connection. Detection back off is helpful for insuring that a midspan and an endpoint do not compete with each other and result in a failure to provide power. With detection back-off, the time between detection pulses is increased to just over two seconds so as not to compete with the normal (approximately three times per second) detection of an endpoint. If detection back-off is required, click the “Midspan” button to toggle this mode. You will see that the LEDs on the connector board now flash at the slower detection speed. To toggle the mode back to standard detection timing, click the button again.

The Si3452 in auto mode is fully-compliant with the 802.3at standard (often called PoE+), which allows up to 30 W to be delivered over the Ethernet cable. To enable the higher power support for a given port, click the “2x power” check box for that port.

In 2x power mode, the Si3452 automatically performs the two-event classification and increases the cut-off current if a class 4 PD is detected. The Si3401 evaluation board provided with the kit is configured to provide the Class 4 signature; so, if the 2x mode is enabled and the Si3401 PD is plugged in, the cut-off current is automatically set to 643 mA. The screen shot in Figure 12 shows the result of plugging in a class 4 PD (into Port1) with 2x power enabled.

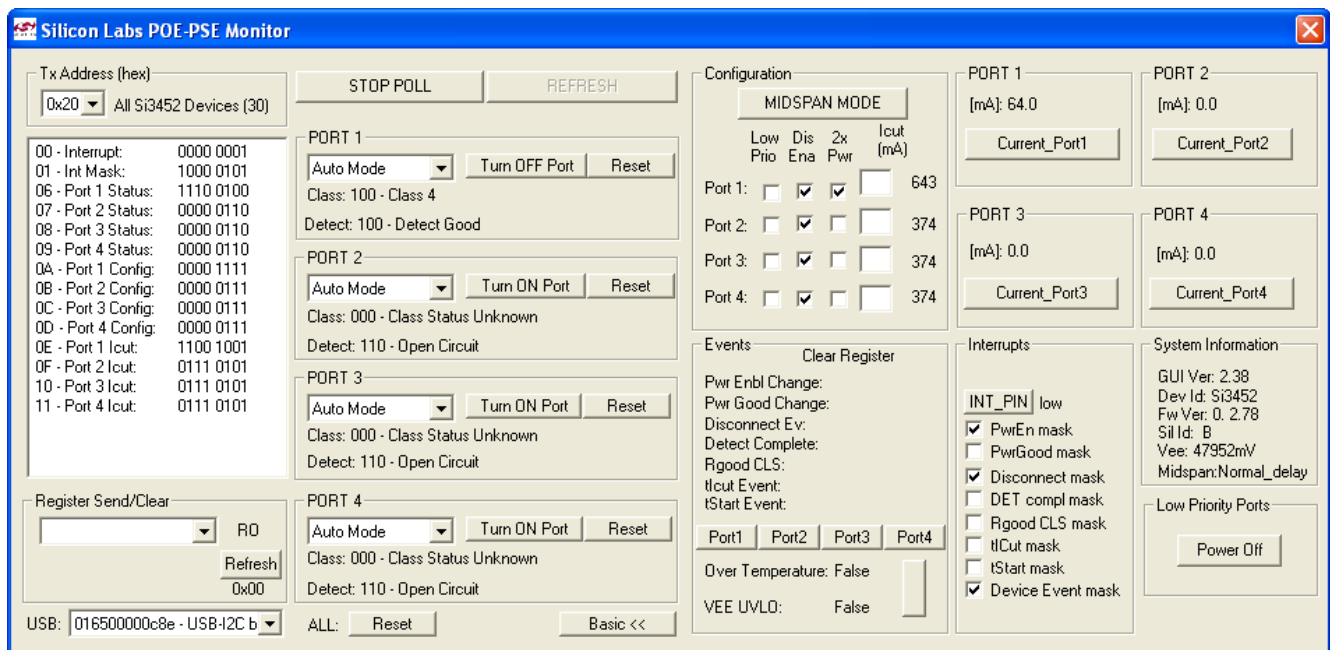

Figure 12. Result of Putting Port 1 into Auto and POE+ Mode and Plugging in the Si3401 Class 4 PD with a 10 Ω Load

7. Board Schematics, BOM, and Layout

The following are general PCB layout considerations. Detailed schematics, BOM, and layout can also be found in the following sections. Visit the Silicon Labs Technical Support web page and register to submit a technical support request, particularly if you are not closely following the recommended reference design.

7.1. Design and Layout Considerations

Due to the high current of up to 800 mA per port, the following board layout guidelines apply.

The VEE1, VEE2, VEE3, and VEE4 pins can carry up to 800 mA and are connected to a VEE bus. The VEE bus for a 4-port PCB layout can thus carry as much as 3.2 A current. The best practice is to devote an entire inner layer for VEE power routing.

Similarly, GND1/2 and GND3/4 pins can carry up to 1.6 A per pin, and the GND return bus should be at least as wide as the VEE bus. The best practice is to devote an entire inner layer for ground power routing.

The ground power plane does not generally have a high frequency content (other than external faults); so, it is generally acceptable to use the ground power plane as a ground signal plane and tie AGND and GND12 and GND34 to this plane as well.

The VOUTn pins carry up to 800 mA dc and up to 5 A in faults; so, a 20 mil trace with wide or multiple vias is also recommended. The VDETn pins also carry fault current; so, this pin connection to VOUTn needs to use 20 mil traces and wide or multiple vias where needed.

The VDD currents are not large; so, it is acceptable to route the VDD nodes on one of the outer layers. If care is taken to avoid disruption of the high-current paths, VDD can be globally routed on one of the power planes and then locally routed on an inner or outer layer.

To avoid coupling between surge events and logic signals, it is recommended that VOUTn traces be routed on the side opposite the I²C interface pins.

The thermal pad of the Si3452/3 is connected to VEE. At full IEEE 802.3at and a current of 600 mA on each port, the dissipation of the Si3452/3 is up to 1.2 W; so, multiple vias are required to conduct the heat from the thermal pad to the VEE plane. As many as 36 small vias provide the best thermal conduction. Heat is dissipated through the Si3452 by vias to a large Vee plane on the back of the board. Chip-to-chip spacing should be kept to greater than one inch to reduce peak temperatures associated with the Si3452 chips from heating each other.

The I²C bus runs at a modest speed of 400 kHz maximum. The I²C bus lines should be routed away from analog lines like Rbias or Vref but can otherwise be routed with ordinary care.

For the Si3452 itself, there are no EMI considerations. The Si3500 dc-to-dc converter in the reference design is a potential EMI source; so, care must be used in routing the FET output (SWO). The lead lengths should be kept short, and SWO should be kept away from the analog nodes. Also, the area enclosed by the paths between the input filter caps to the inductor and returning to SWO and Vss and also from the output filter caps to the inductor and returning through the diode should be minimized. Following the reference design closely in this area will insure success.

7.2. Si3452 Schematics

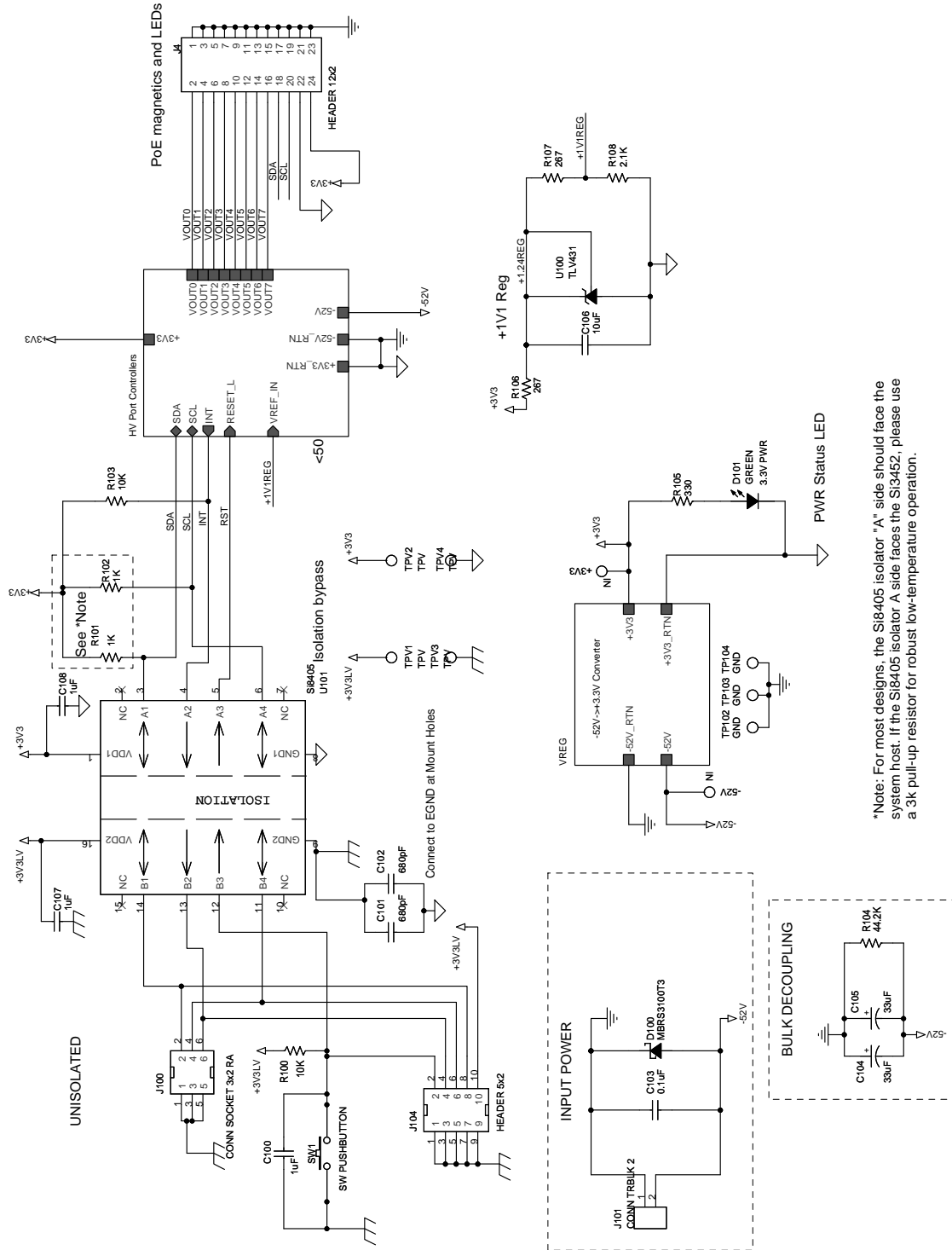

*Note: For most designs, the Si8405 isolator "A" side should face the system host. If the Si8405 isolator A side faces the Si3452, please use a 3k pull-up resistor for robust low-temperature operation.

Figure 13. Top Level

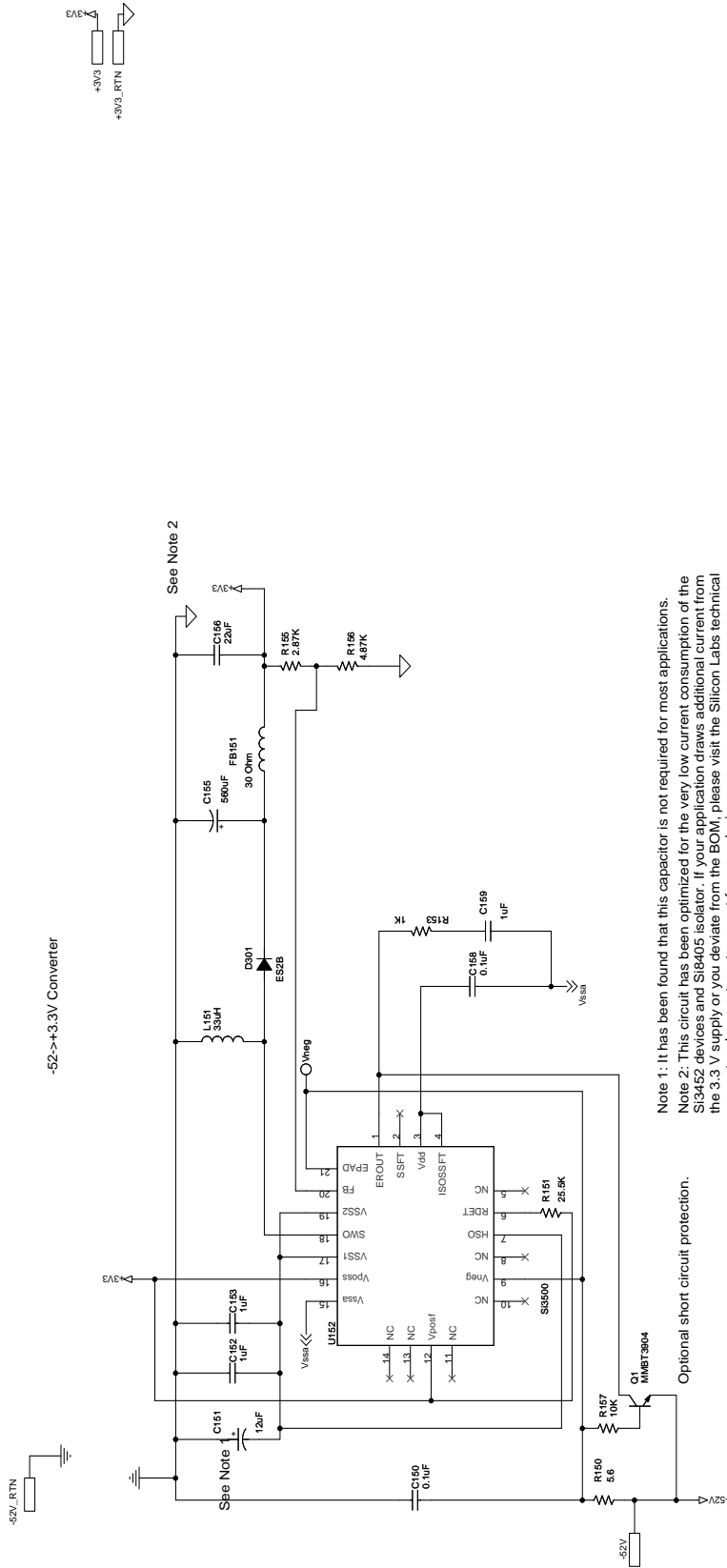

Note 1: It has been found that this capacitor is not required for most applications.
 Note 2: This circuit has been optimized for the very low current consumption of the Si3452 devices and Si8405 Isolator. If your application draws additional current from the 3.3 V supply or you deviate from the BOM, please visit the Silicon Labs technical support web page to get support for your design.

Figure 14. DC-DC Converter

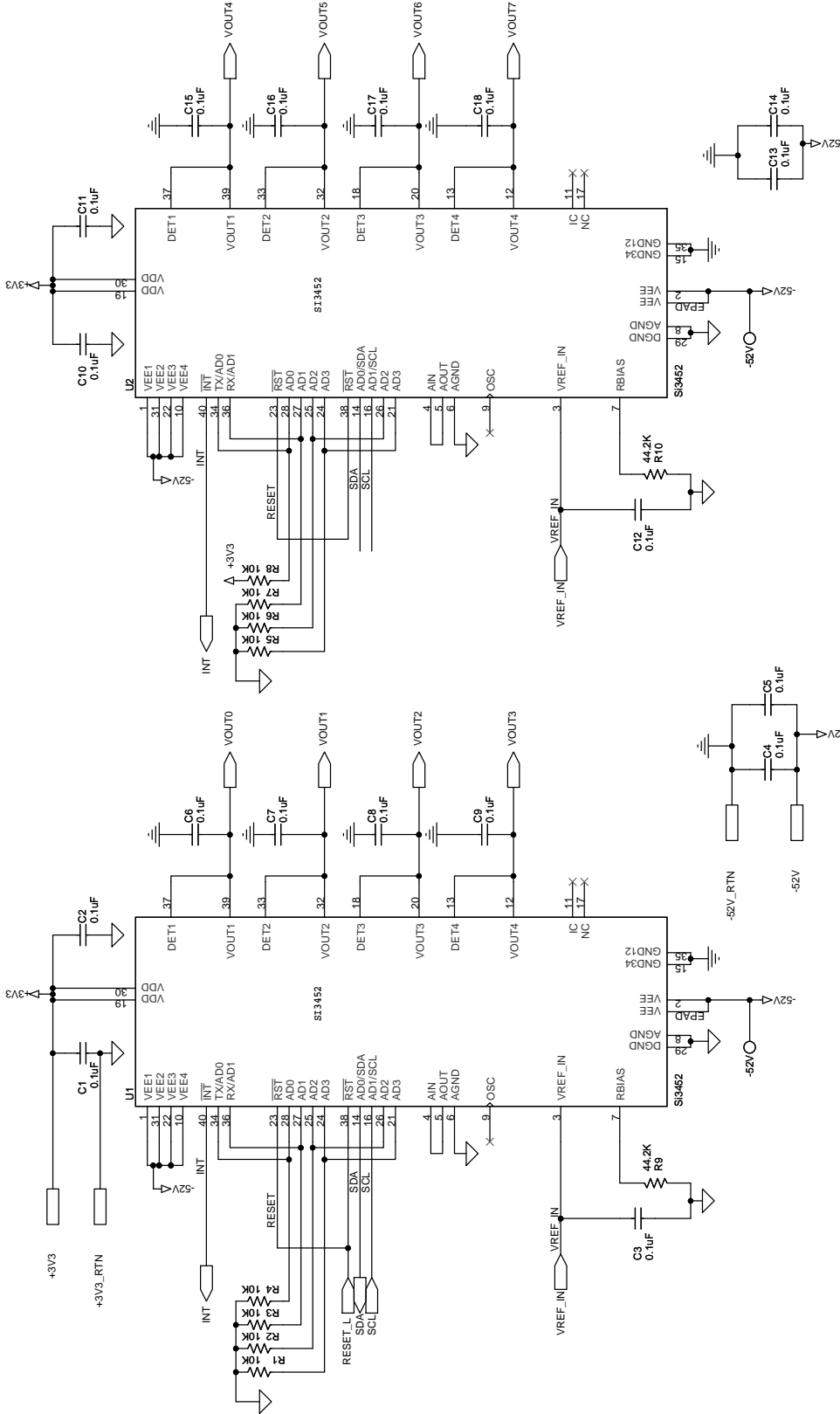

Figure 15. Si3452 Controllers

Si3452MS8-KIT

7.3. Si3452 Layout

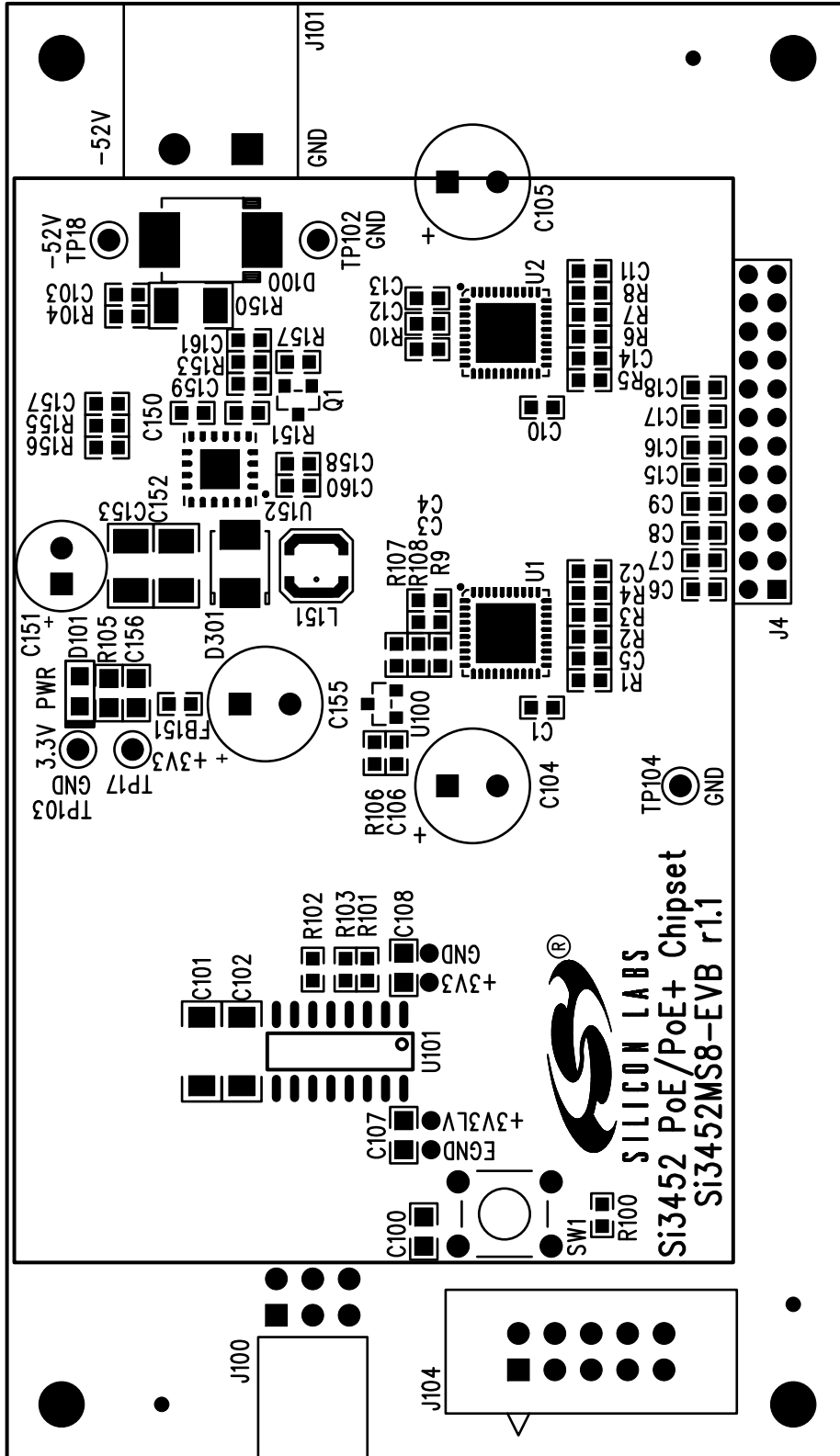

Figure 16. Si3452 Top Silkscreen

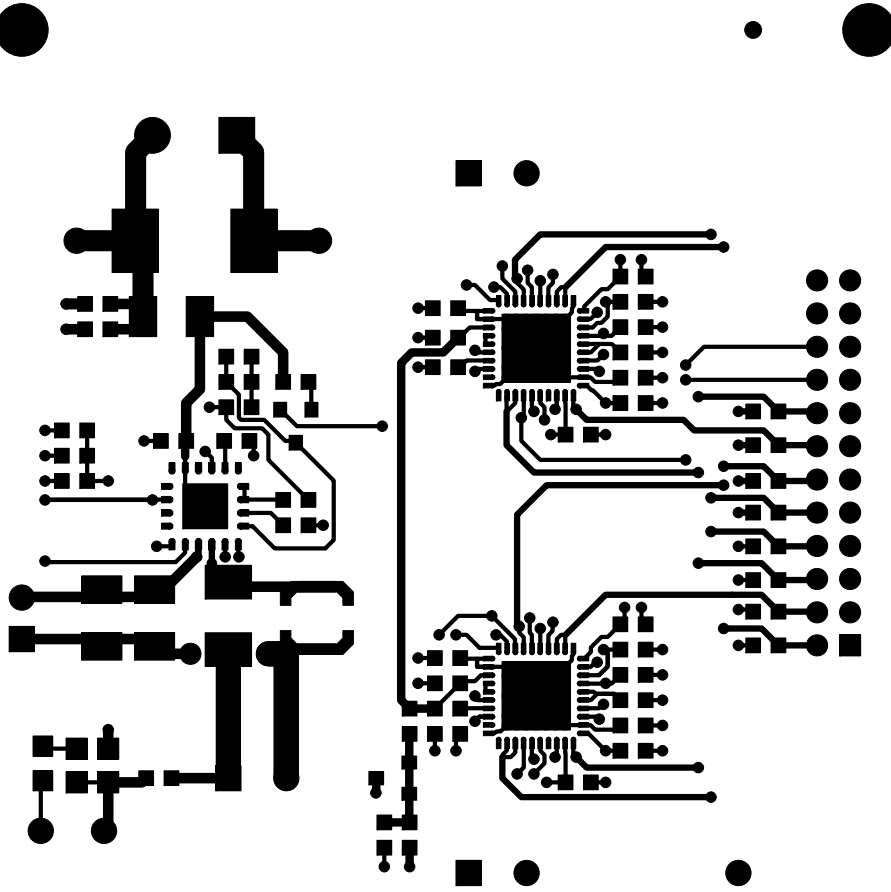
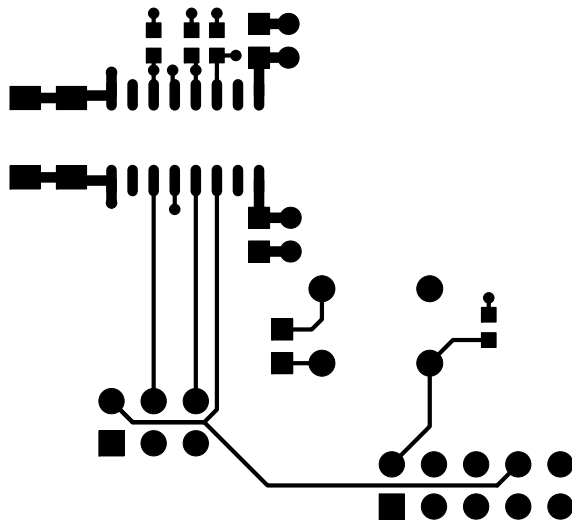

Figure 17. Si3452 Primary Side



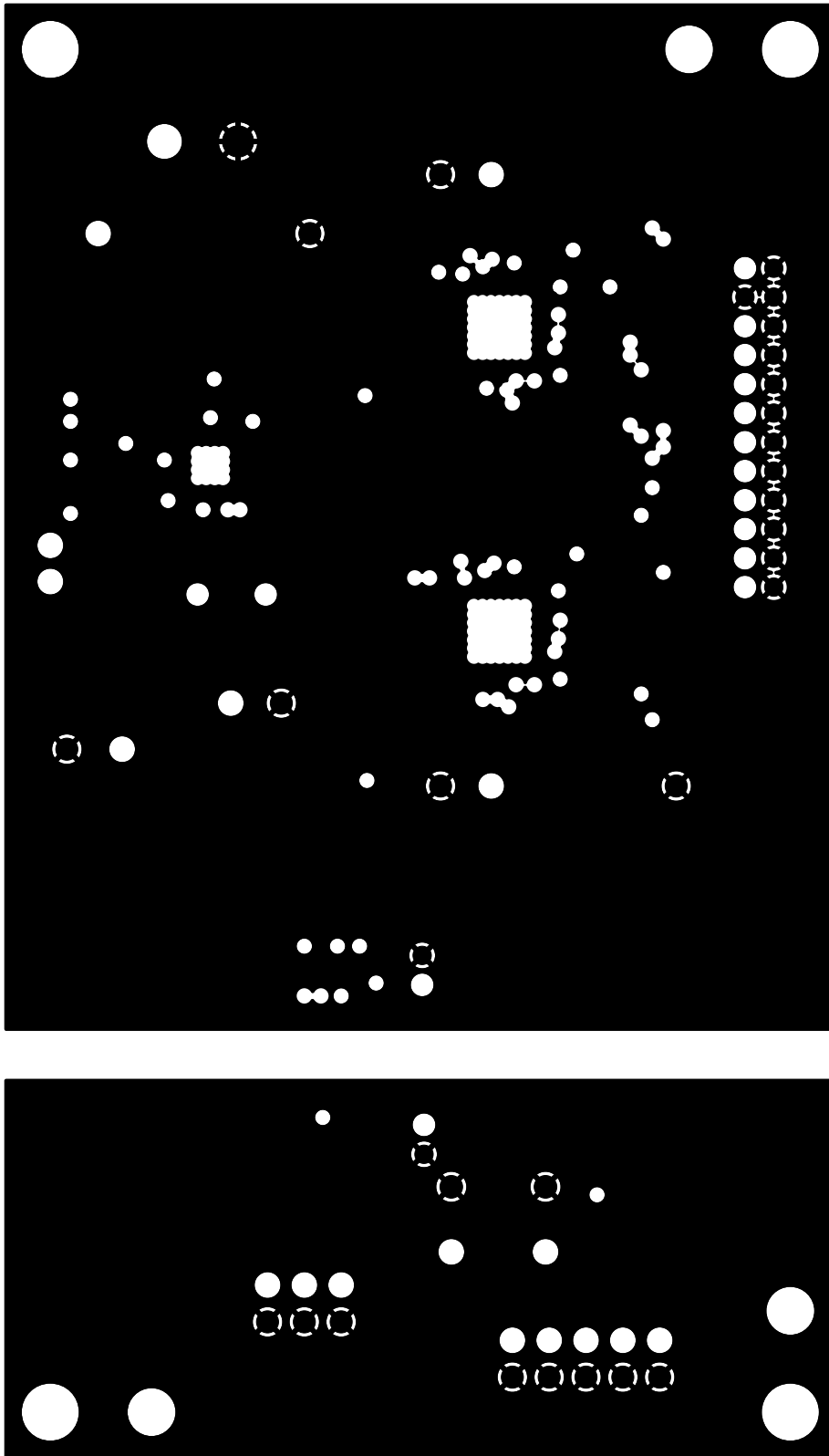

Figure 18. Si3452 Ground Plane

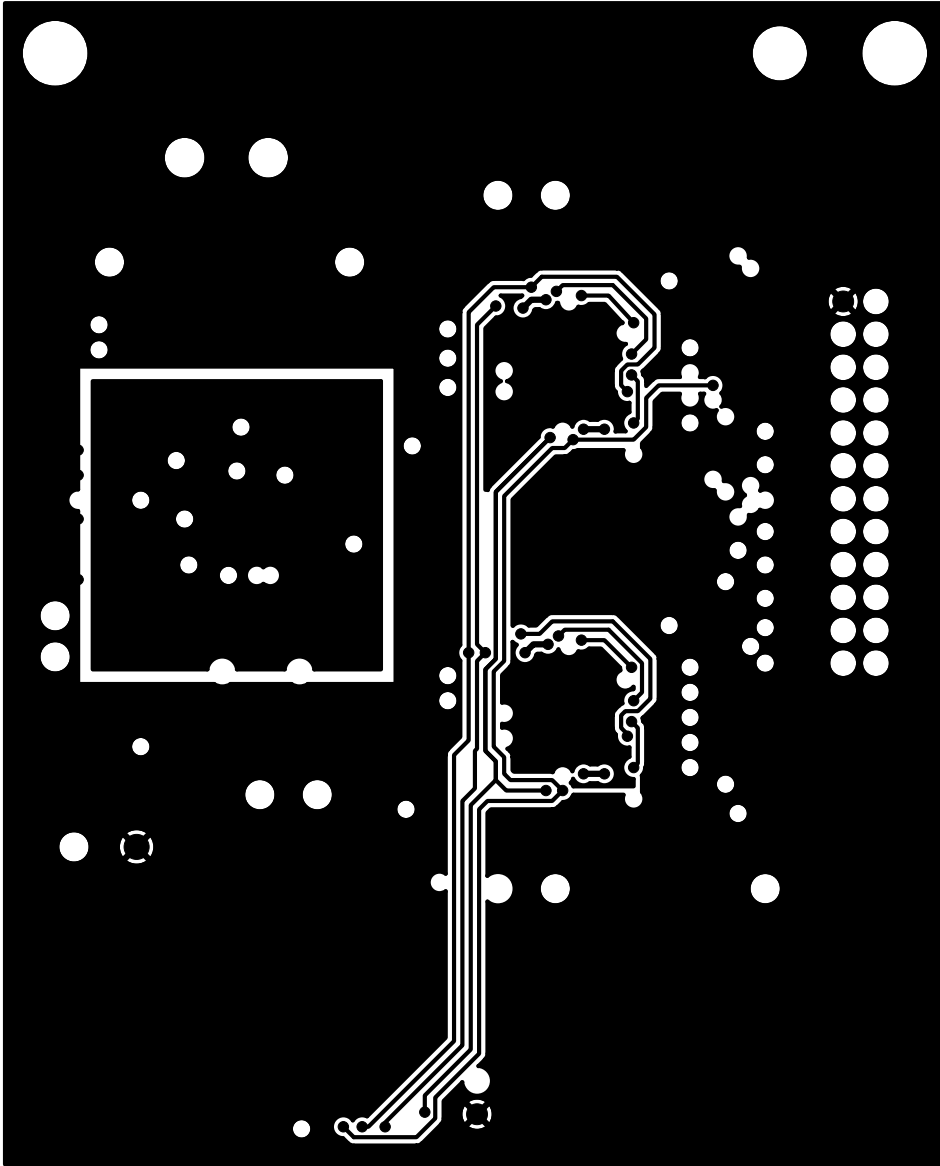
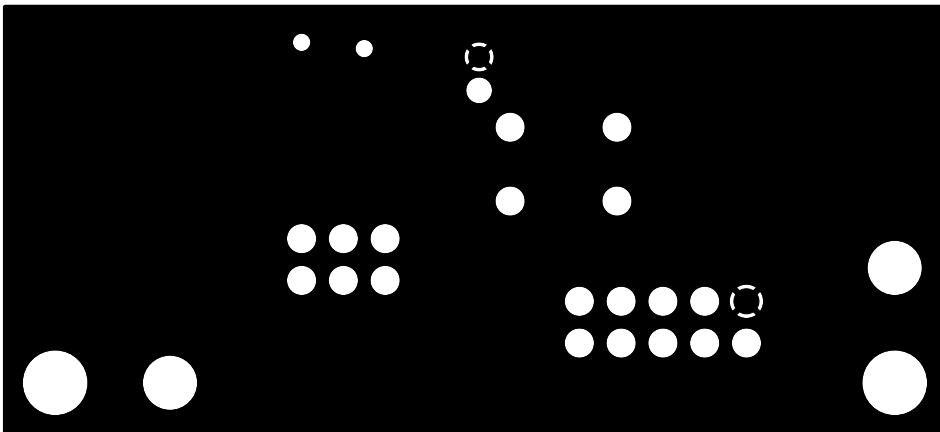

Figure 19. Si3452 Power Plane



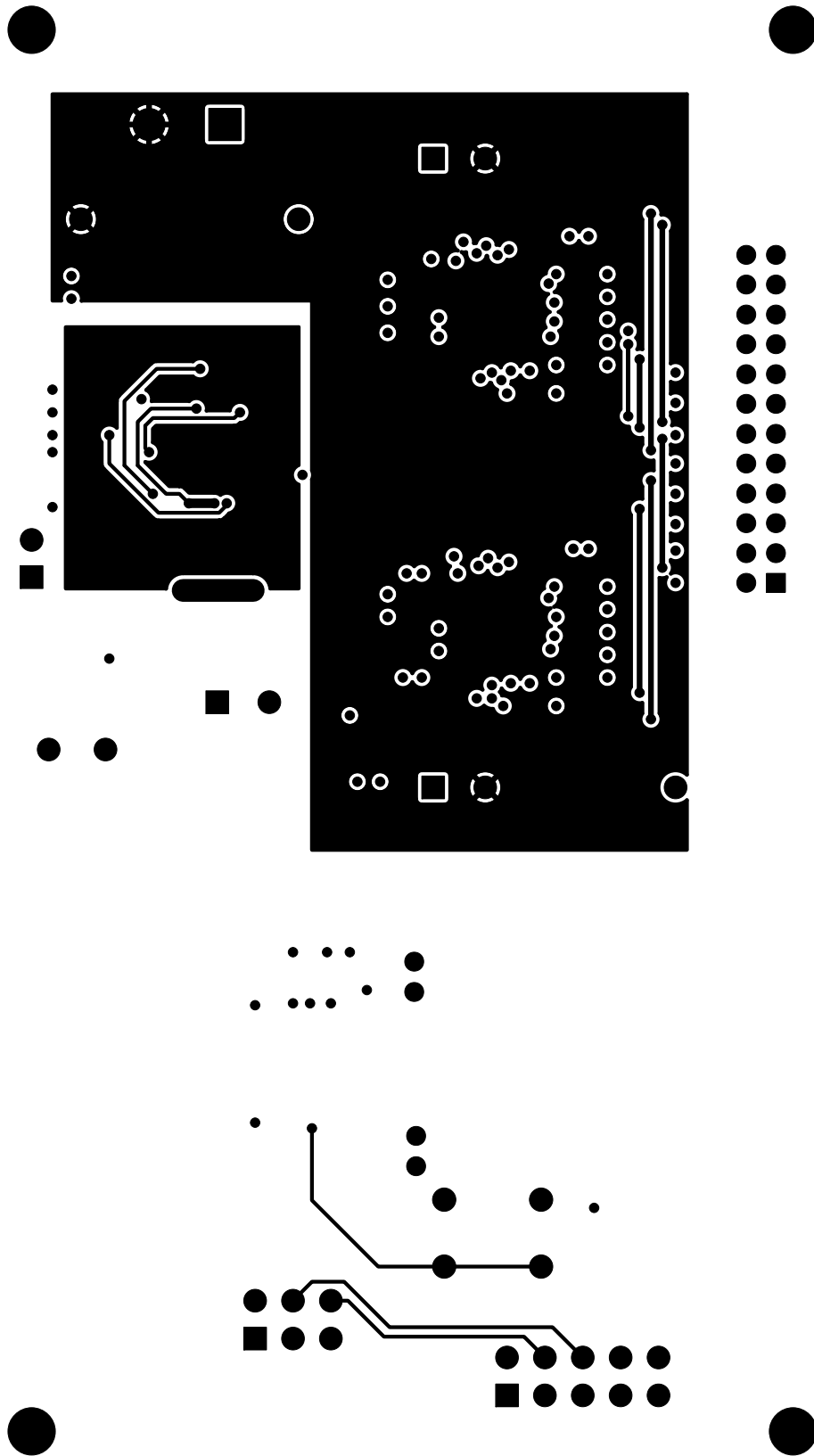

Figure 20. Si3452 Secondary Side

7.4. Si3452 Bill of Materials

Table 2. Si3452 Bill of Materials

Item	Qty	Reference	Value	Rating and Voltage	Tol	Type	PCB Footprint	Manufacturer Part Number	Manufacturer
1	6	C1,C2,C3,C10,C11,C12	0.1 μ F	16 V	\pm 20%	X7R	C0603	C0603X7R160-104M	Venkel
2	14	C4,C5,C6,C7,C8,C9,C13,C14,C15,C16,C17,C18,C103,C150	0.1 μ F	100 V	\pm 20%	X7R	C0603	C0603X7R101-104M	Venkel
3	3	C100,C017,C108	1 μ F	16 V	\pm 20%	X7R	C0805	C0805X7R160-105M	Venkel
4	2	C101,C102	680 pF	250 V	\pm 15%	Y3	C1808	GA342QR7GD681K W01L	Murata
5	2	C104,C105	33 μ F	100 V	\pm 20%	Alum Elec	C3.5X8MM-RAD	ECA2AM330	Panasonic
6	1	C106	10 μ F	6.3 V	\pm 20%	X5R	C0603	C0603X5R6R3-106M	Venkel
7	1	C151*	12 μ F	100 V	\pm 20%	Alum Elec	C2.5X6.3MM-RAD	EEUFC2A120	Panasonic
8	2	C152,C153	1 μ F	100 V	\pm 10%	X7R	C1210	C1210X7R101-105K	Venkel
9	1	C155	560 μ F	6.3 V	\pm 20%	Alum Elec	C3.5X8MM-RAD	EEUFM0J561	Panasonic
10	1	C156	22 μ F	6.3 V	\pm 20%	X5R	C0805	C0805X5R6R3-226M	Venkel
11	1	C157							
12	1	C158	0.1 μ F	25 V	\pm 10%	X7R	C0603	C0603X7R250-104K	Venkel
13	1	C159	1 μ F	10 V	\pm 10%	X7R	C0603	C0603X7R100-105K	Venkel
14	1	C160							
15	1	C161							
16	1	D100	MBRS3100T3	3 A,100 V		Schottky	DO-214AB	MBRS3100T3	On Semi
17	1	D101	Green	30 mA, 2.2 V		SMT	LED-0805-K	LTST-C170GKT	LITE_ON INC
18	1	D301	ES2B	2.0 A, 100 V		Single	DO-214AA	ES2B	Diodes Inc
19	1	FB151	BLM18PG300SN1	1000 mA		SMT	L0603	BLM18PG300SN1	MuRata
20	1	J4	HEADER 12x2			Header	CONN-2X12-2MM	TMM-112-01-T-D	Samtec
21	1	J100	CONN SOCKET 3x2 RA			Socket	CONN2X3-FRA	SSQ-103-02-G-D-RA	Samtec
22	1	J101	CONN TRBLK 2			Term Blk Male	CONN-TB-1757242	1757242	PHOENIX CONTACT

*Note: See schematic notes in Figures 13 and 14.

Si3452MS8-KIT

Table 2. Si3452 Bill of Materials (Continued)

Item	Qty	Reference	Value	Rating and Voltage	Tol	Type	PCB Footprint	Manufacturer Part Number	Manufacturer
23	1	J104	HEADER 5x2			Header	CONN2X5-4W	TSW-105-07-T-D	Samtec
24	1	L151	33 μ H	0.4 A	\pm 20%	Shielded	IND-4018	LPS4018-333	Coilcraft
25	1	Q1	MMBT3904	200 mA, 40 V		NPN	SOT23-BEC	MMBT3904	Fairchild
26	9	R1,R2,R3,R4, R5,R6,R7,R8, R157	10 k Ω	1/10 W	\pm 5%	Thick-Film	R0603	CR0603-10W-103J	Venkel
27	3	R9,R10,R104	44.2 k Ω	1/10 W	\pm 1%	Thick-Film	R0603	CR0603-10W-4422F	Venkel
28	2	R100,R103	10 k Ω	1/10 W	\pm 1%	Thick-Film	R0603	CR0603-10W-1002F	Venkel
29	3	R101,R102, R153*	1 k Ω	1/10 W	\pm 1%	Thick-Film	R0603	CR0603-10W-1001F	Venkel
30	1	R105	330 Ω	1/10 W	\pm 1%	Thick-Film	R0805	CR0805-10W-3300F	Venkel
31	2	R106,R107	267 Ω	1/10 W	\pm 1%	Thick-Film	R0603	CR0603-10W-2670F	Venkel
32	1	R108	2.1 k Ω	1/16 W	\pm 1%	Thick-Film	R0603	CR0603-16W-2101F	Venkel
33	1	R150	5.6 Ω	1/4 W	\pm 5%	Thick-Film	R1210	CR1210-4W-5R6J	Venkel
34	1	R151	25.5 k Ω	1/16 W	\pm 1%	Thick-Film	R0603	CR0603-16W-2552F	Venkel
36	1	R155	2.87 k Ω	1/16 W	\pm 1%	Thick-Film	R0603	CR0603-16W-2871F	Venkel
37	1	R156	4.87 k Ω	1/16 W	\pm 1%	Thick-Film	R0603	CR0603-16W-4871F	Venkel
38	1	SW1	SW PUSHBUT-TON	50 mA, 12 Vdc			SW-PB-MOM	101-0161-EV	Mountain Switch
40	1	TP17	Test Point			Red	TESTPOINT	151-207	Kobiconn
41	1	TP18	Test Point			White	TESTPOINT	151-201	Kobiconn
42	3	TP102,TP103, TP104	Test Point			Black	TESTPOINT	151-230	Kobiconn
43	2	U1,U2	Si3452	-70 V		POE	QFN40N6X6P0.5	Si3452	SiLabs
44	1	U100	TLV431	7 V		SHUNT	TLV431-DBZ	TLV431BCDBZR	TI
45	1	U101	Si8405	2500 V _{RMS}		Isolator	SO16N6.0P1.27	Si8405	SiLabs
46	1	U152	Si3500	-70 V		DC-DC	QFN20N5X5P0.8	Si3500	SiLabs

***Note:** See schematic notes in Figures 13 and 14.

7.5. RJ45 Connector Board Schematics

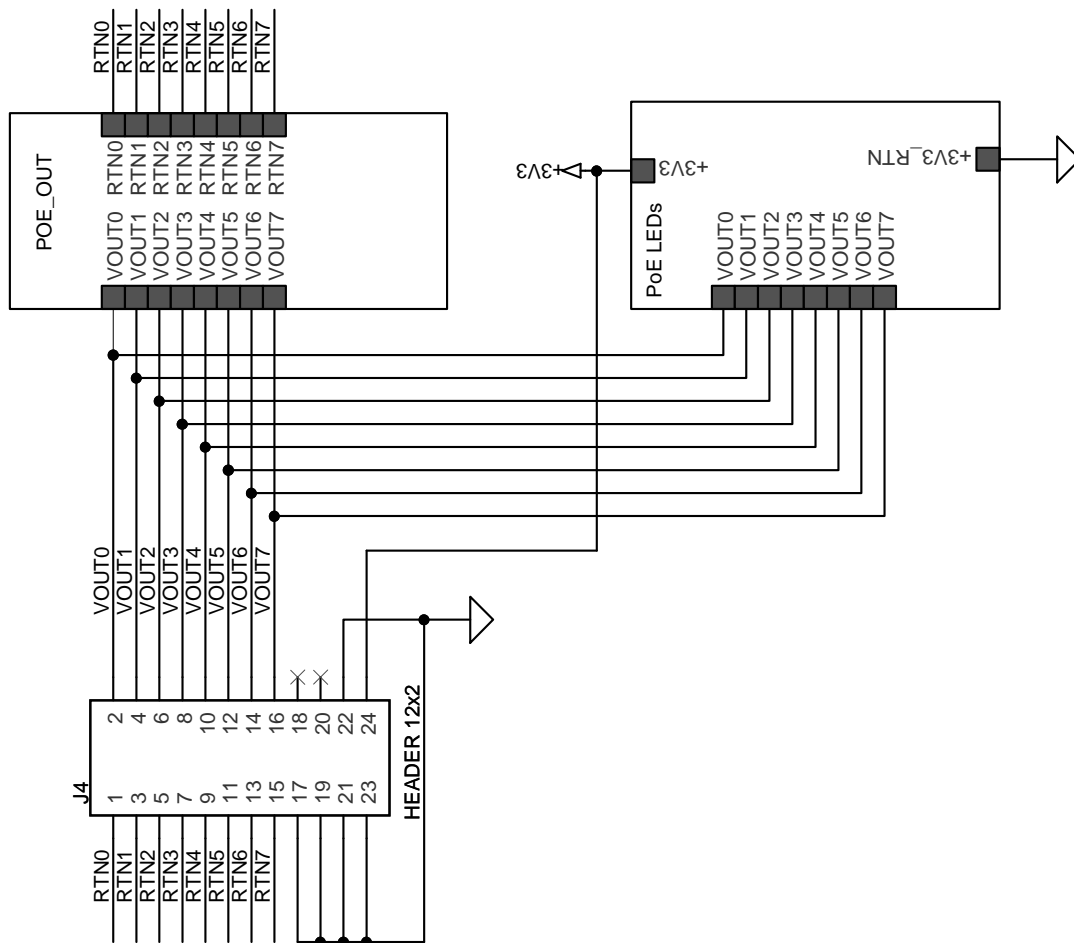

Figure 21. Top Level

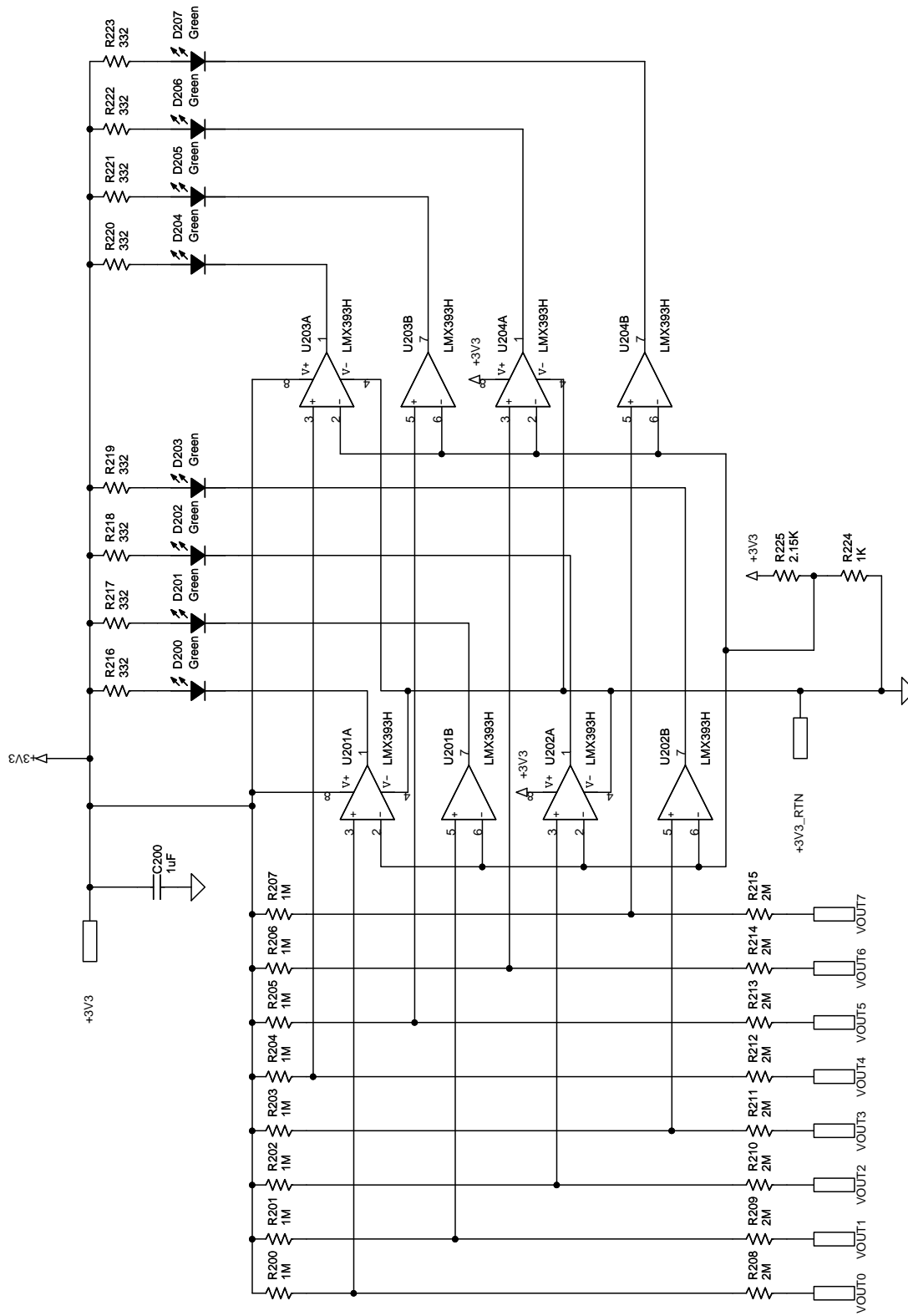

Figure 22. LED Drivers

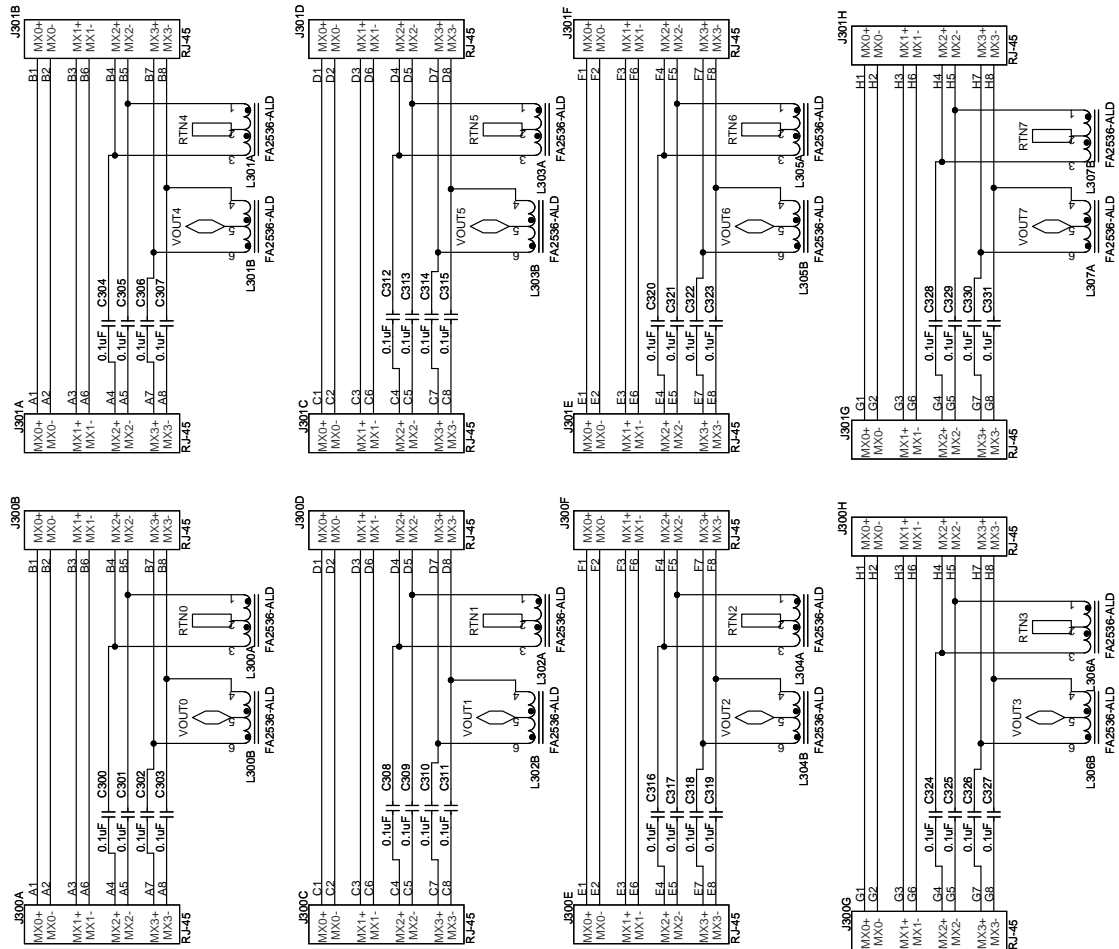

Figure 23. Connectors and Coupling Circuits

7.6. RJ45 Connector Board Layout

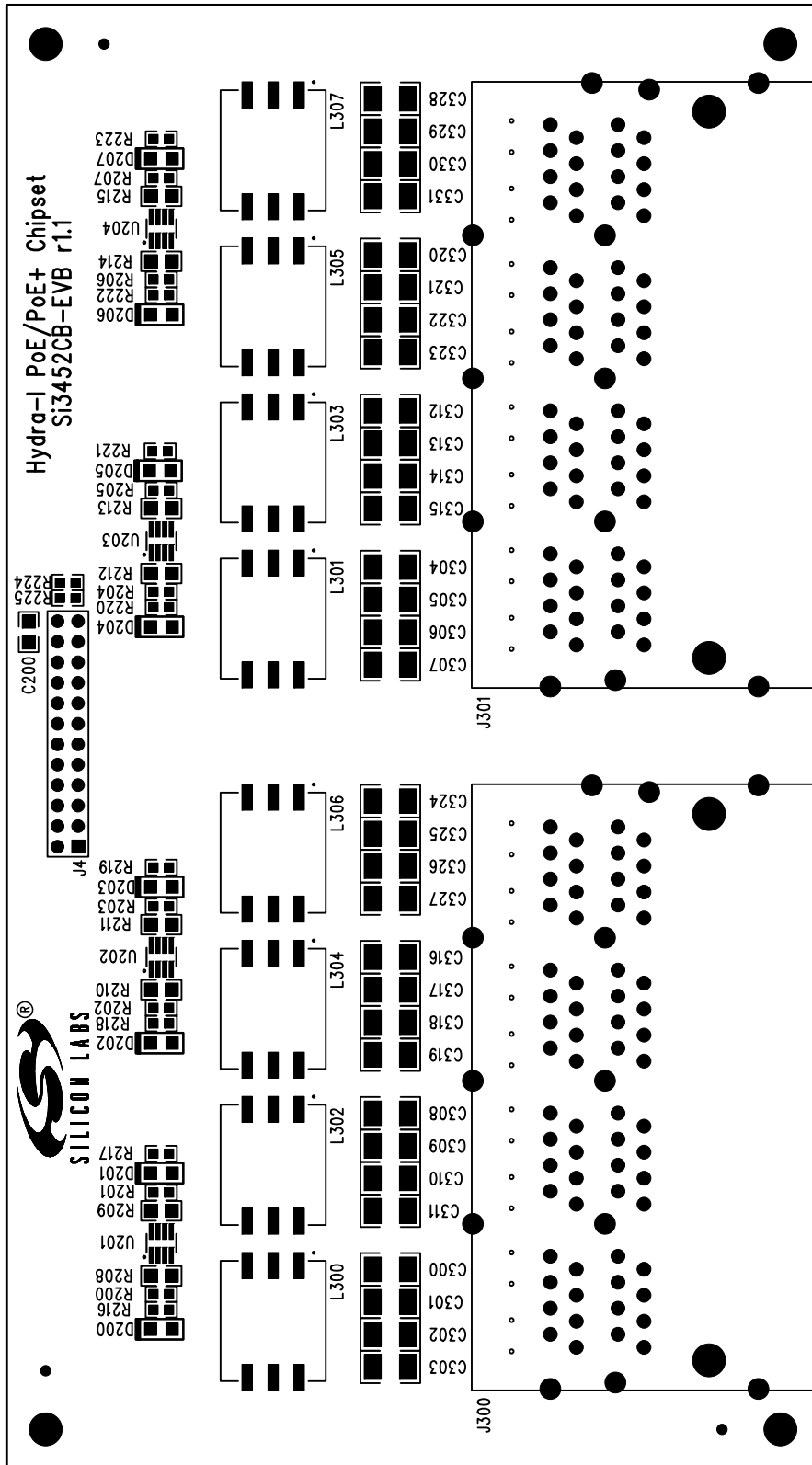

Figure 24. RJ-45 Top Silkscreen

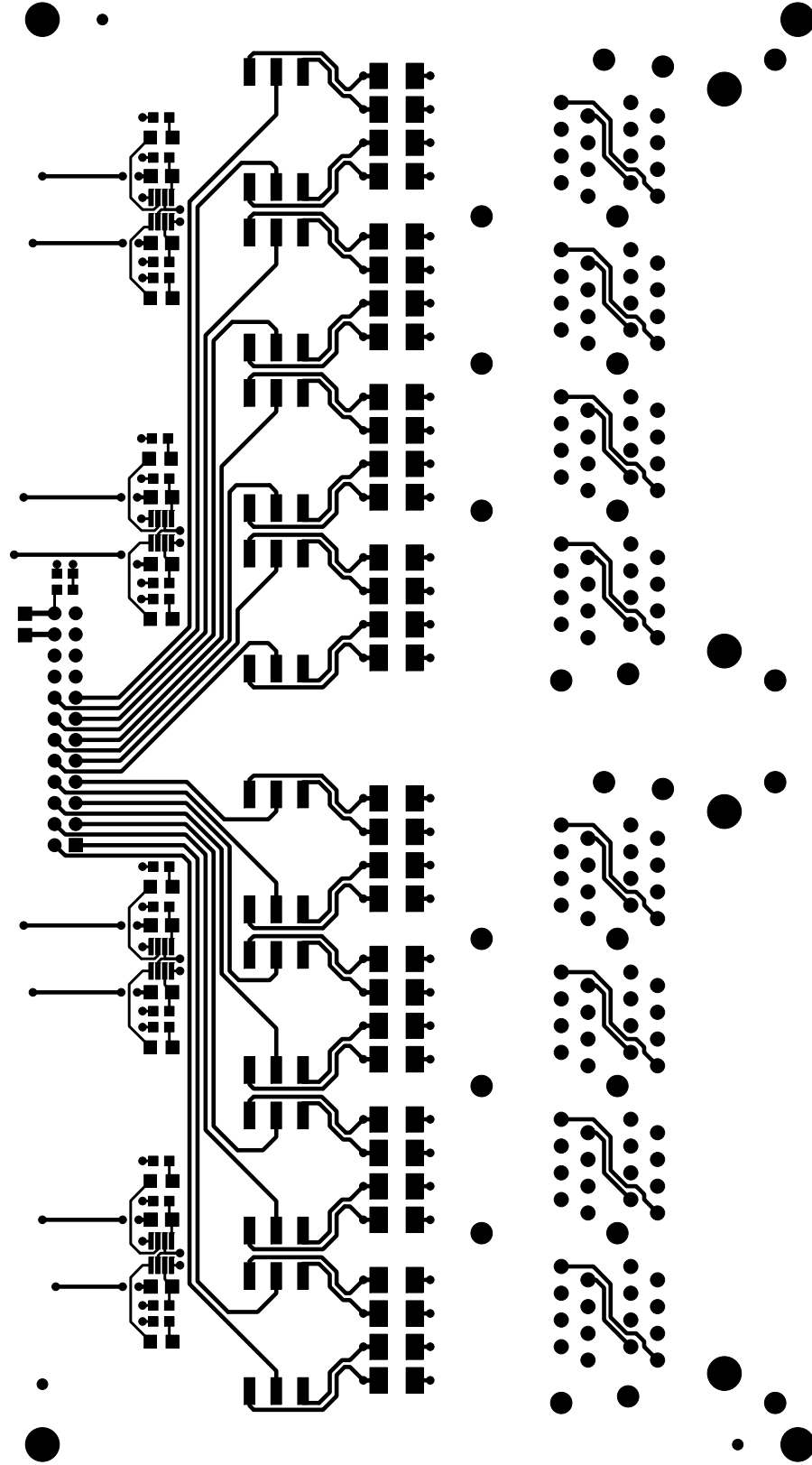

Figure 25. RJ45 Primary Side

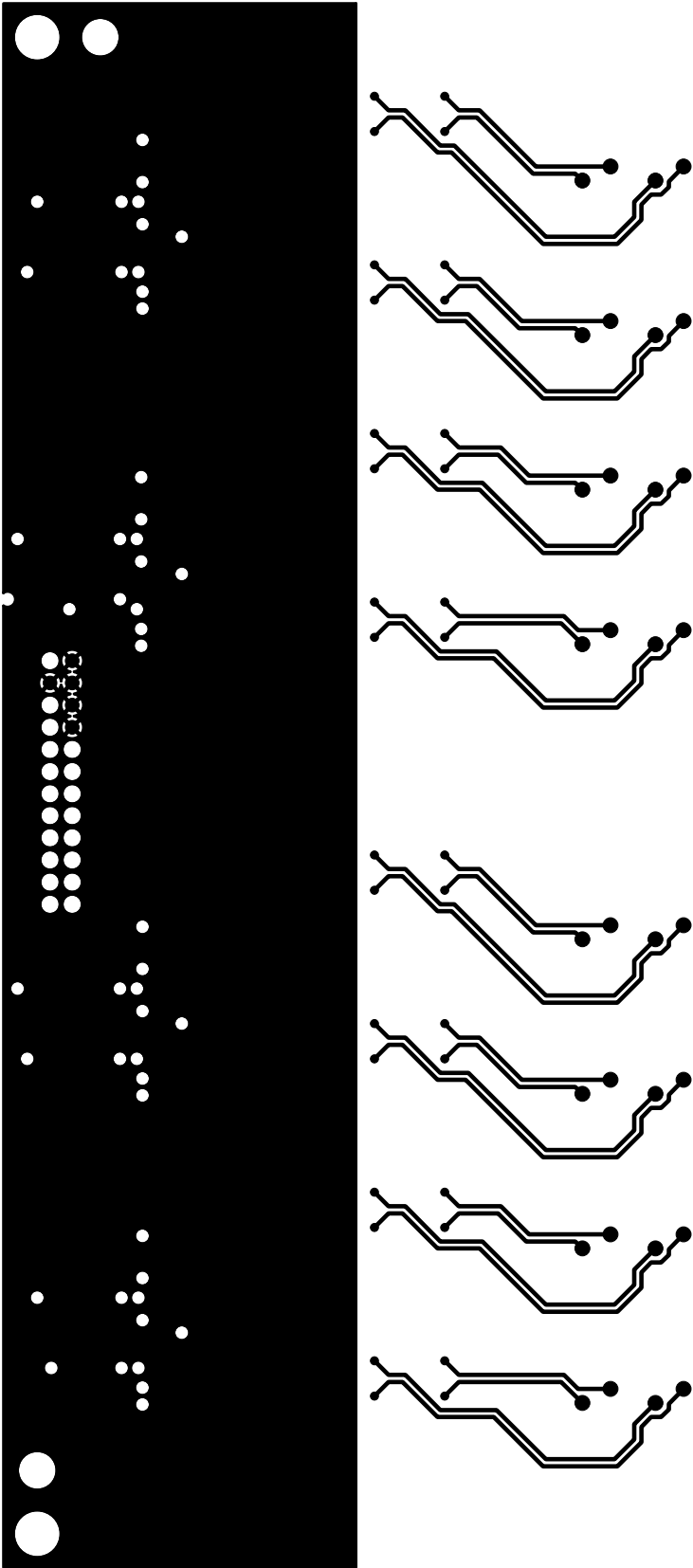

Figure 26. RJ45 Ground Plane

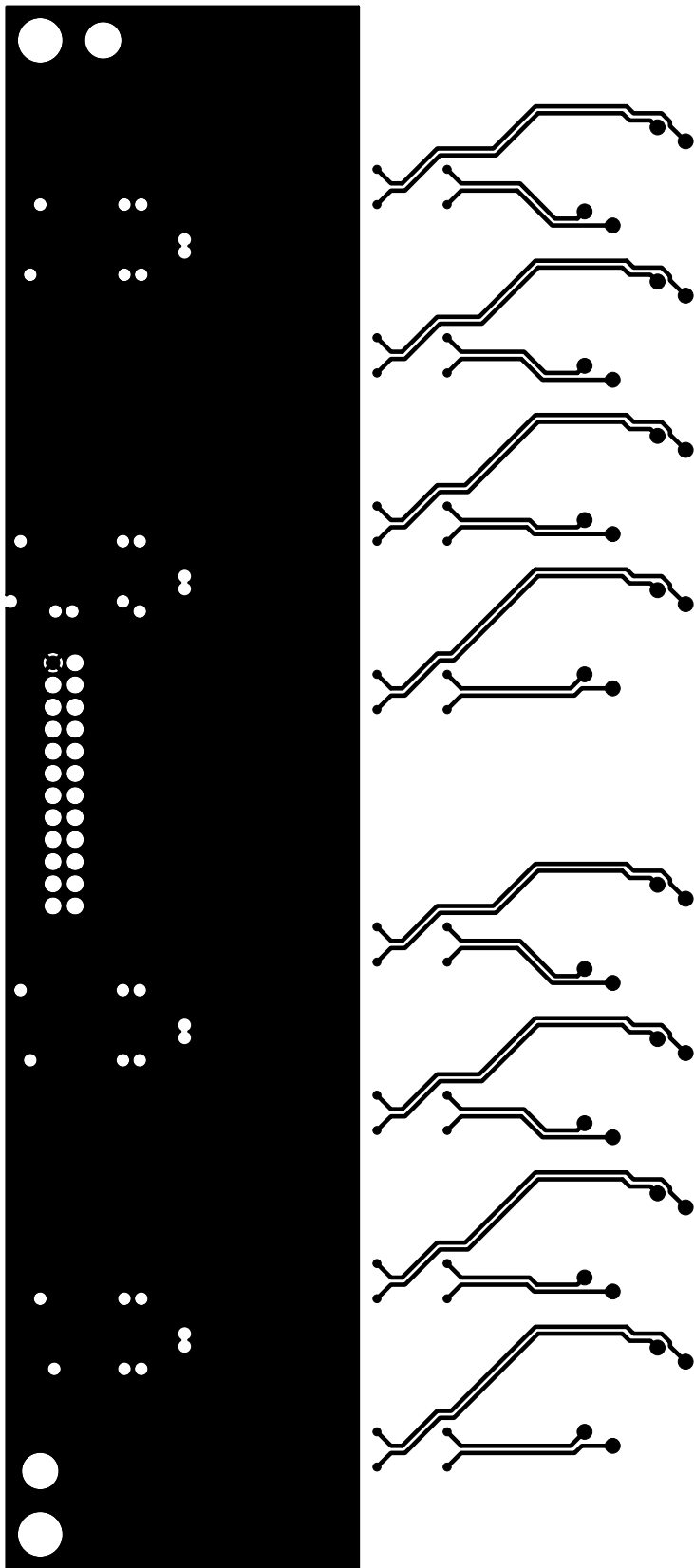

Figure 27. RJ45 Power Plane

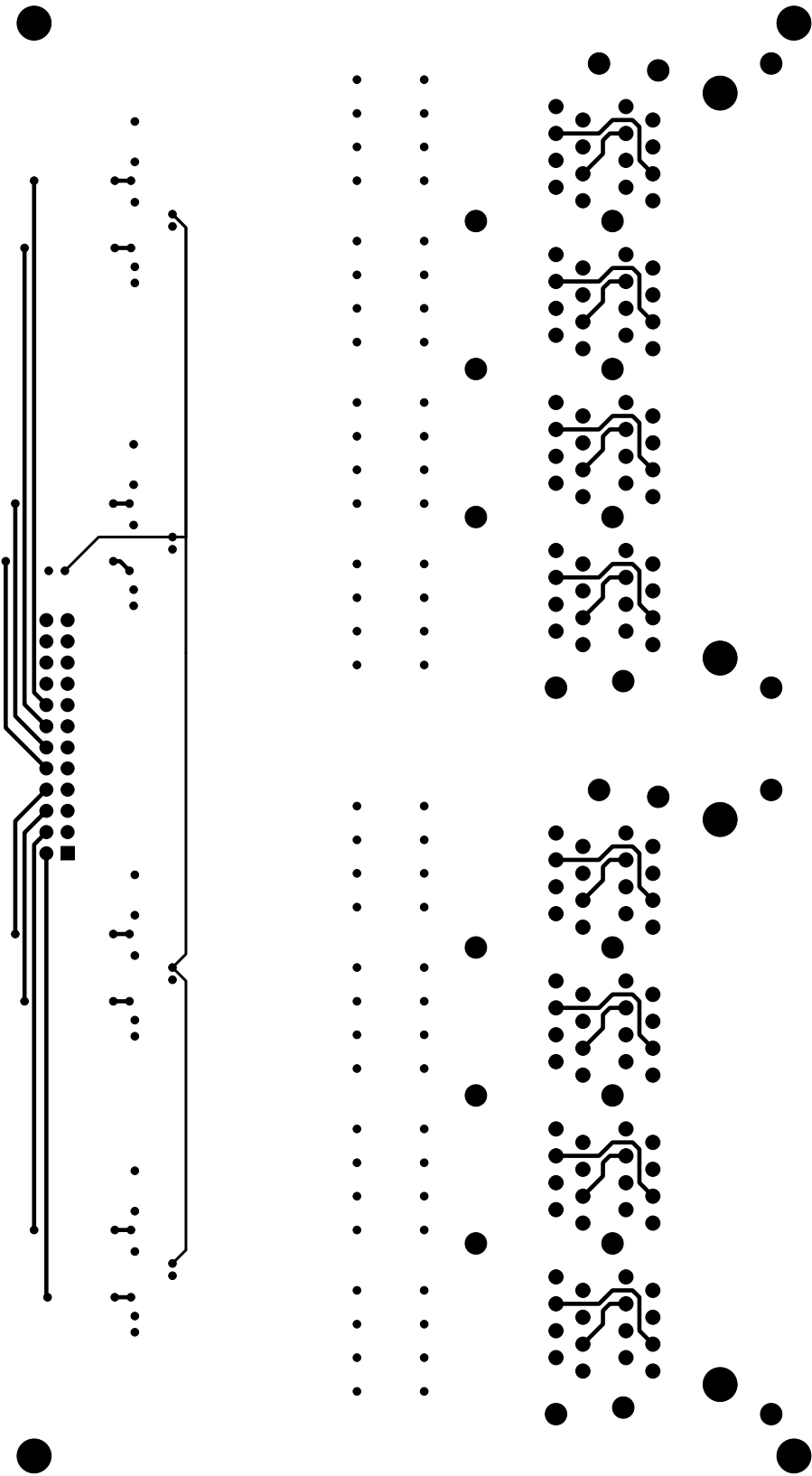

Figure 28. RJ45 Secondary Side

7.7. RJ45 Connector Board Bill of Materials

Table 3. RJ45 Bill of Materials

Item	Qty	Ref	Value	Rating	Tol	PCB Footprint	Mfr Part Number	Mfr
1	1	C200	1 μ F		$\pm 20\%$	C0805	C0805X7R160-105M	Venkel
2	32	C300,C301,C302, C303,C304,C305, C306,C307,C308, C309,C310,C311, C312,C313,C314, C315,C316,C317, C318,C319,C320, C321,C322,C323, C324,C325,C326, C327,C328,C329, C330,C331	0.1 μ F		$\pm 20\%$	C1210	C1210X7R251-104M	Venkel
3	8	D200,D201,D202, D203,D204,D205, D206,D207	Green	30 mA		LED-0805-K	LTST-C170GKT	LITE_ON INC
4	1	J4	CONN Header 12x2			CONN-2X12-2MM	TMM-112-01-T-D	Samtec
5	2	J300,J301	RJ-45			RJ45-8PORT	44170-0001	MOLEX
6	8	L300,L301,L302, L303,L304,L305, L306,L307	FA2536-ALD	675 μ H		FA2536-AL	FA2536-ALD	COIL- CRAFT
7	8	R200,R201,R202, R203,R204,R205, R206,R207	1 M Ω	1/16 W	$\pm 1\%$	R0603	CR0603-16W-1004F	Venkel
8	8	R208,R209,R210, R211,R212,R213, R214,R215	2 M Ω	1/8 W	$\pm 5\%$	R0805	CR0805-8W-205J	Venkel
9	8	R216,R217,R218, R219,R220,R221, R222,R223	332 Ω	1/10 W	$\pm 1\%$	R0603	CR0603-10W-3320F	Venkel
10	1	R224	1 k Ω	1/16 W	$\pm 1\%$	R0603	CR0603-16W-1001F	Venkel
11	1	R225	2.15 k Ω	1/10 W	$\pm 1\%$	R0603	CR0603-10W-2151F	Venkel
12	4	U201,U202,U203, U204	LMX393H	714 mW		SOT23-8N	LMX393HAKA-T	MAXIM IC

Checking whether Driver is Installed

To check whether the driver is installed, perform the following steps:

1. Open the Control Panel and click the System icon.

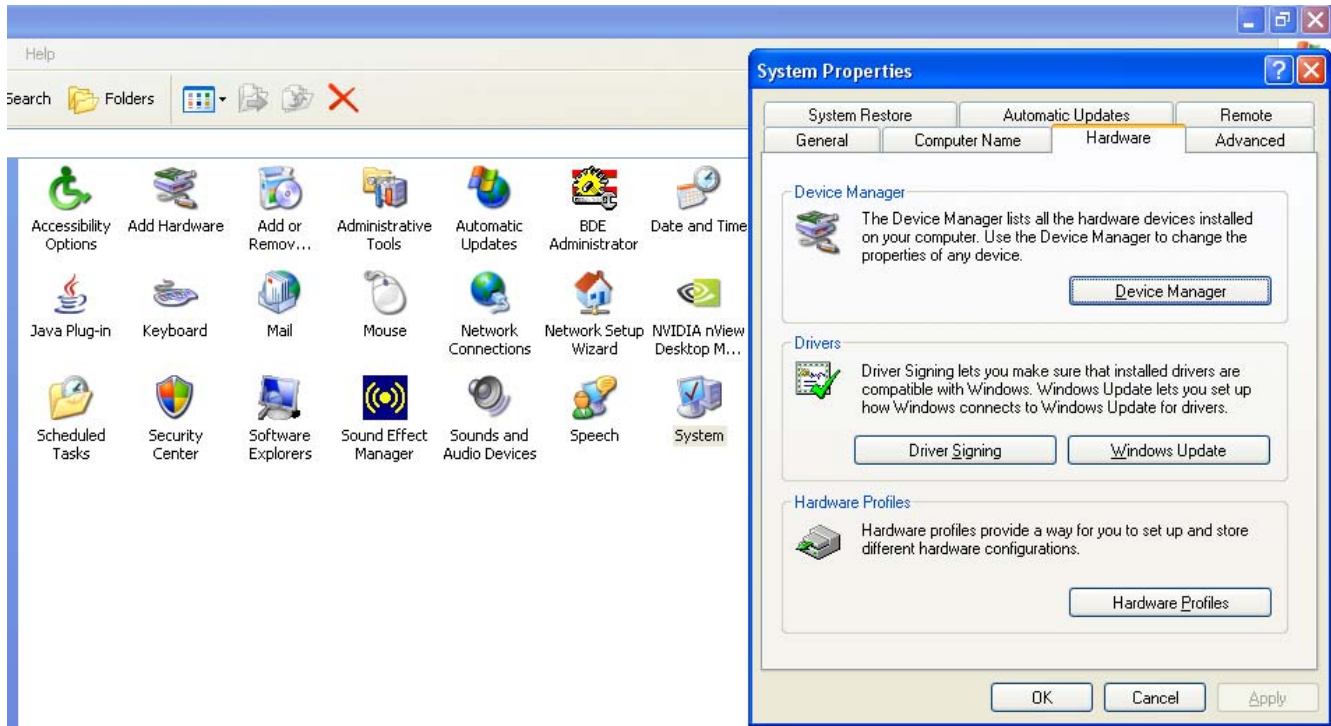

Figure 29. Control Panel

2. Select “Hardware” and click Device Manager. The screen shown in Figure 30 will appear.

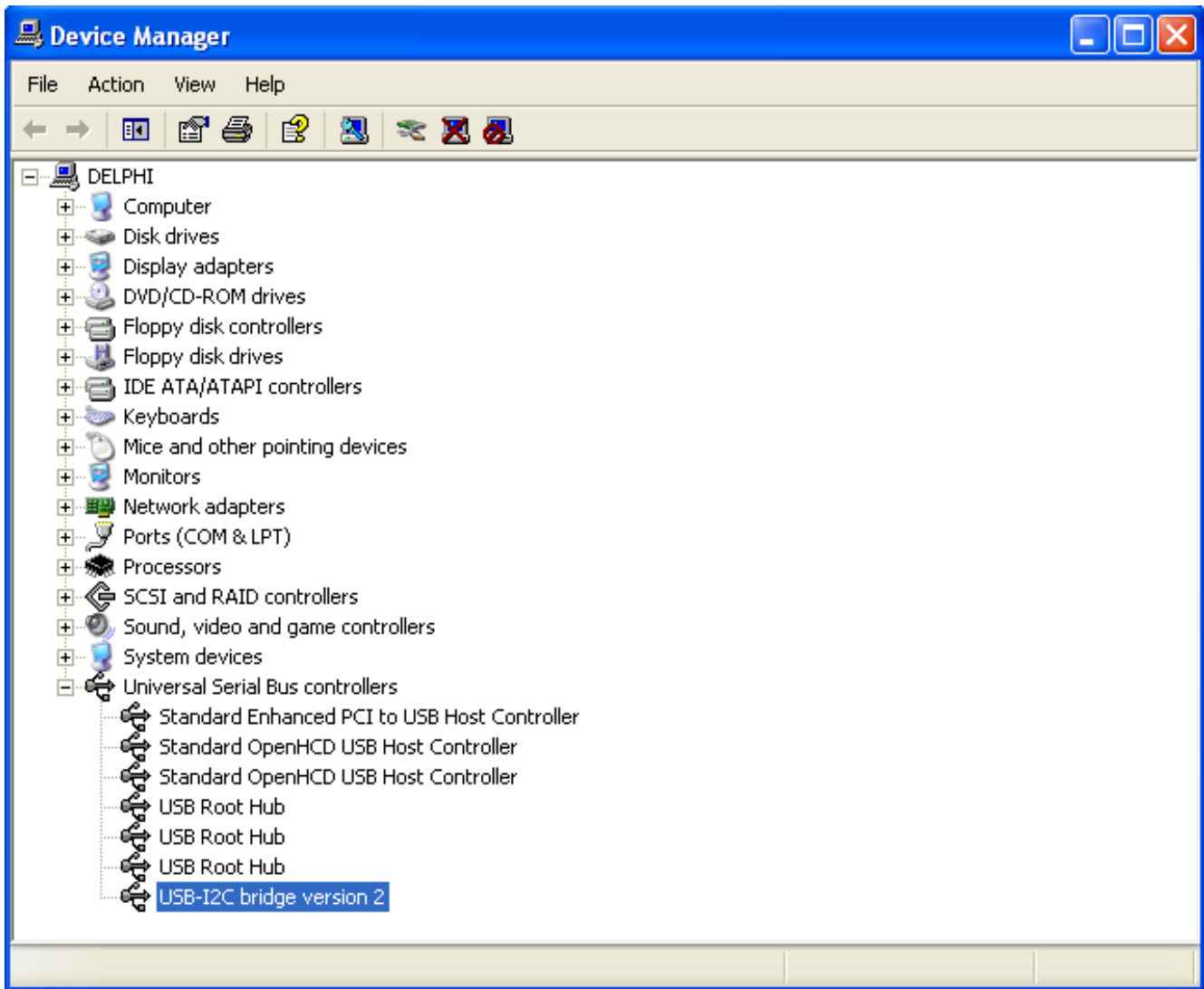

Figure 30. Device Manager

3. Click on “Universal Serial Bus Controllers”, and, if it has installed, it will appear as “USB-I2C bridge version 2”.

Si3452MS8-KIT

Uninstalling the USB to I²C Driver

To uninstall the USB to I²C driver, perform the following steps:

1. Open Control Panel and click the Add or Remove Programs icon.

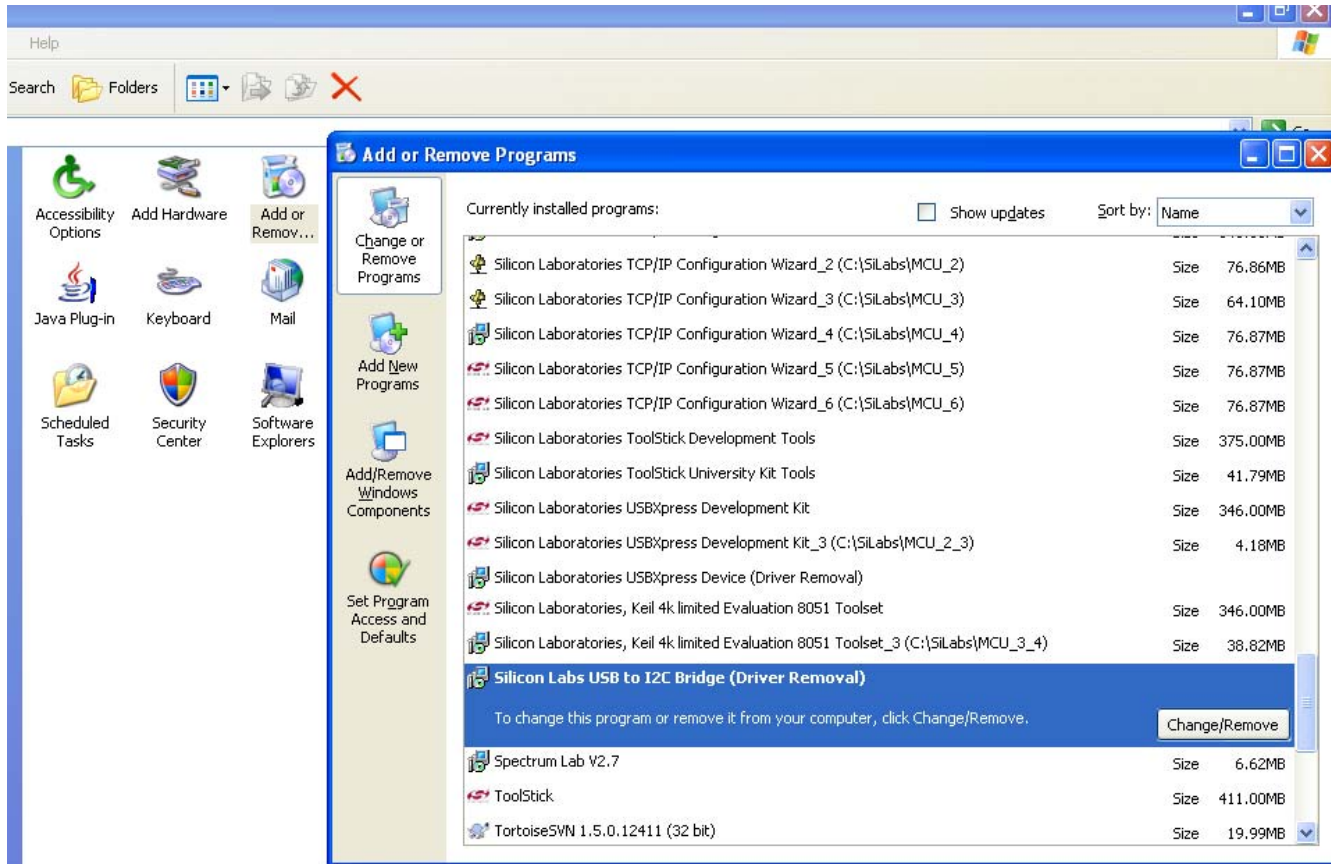

Figure 31. Add/Remove Programs

2. Search “Silicon Labs USB to I2C” and click on Change/Remove button to uninstall the driver.

Uninstalling the Si3452 Monitor GUI

To uninstall the Si3452 monitor GUI, select it from “Add/Remove Programs” in the Control Panel.

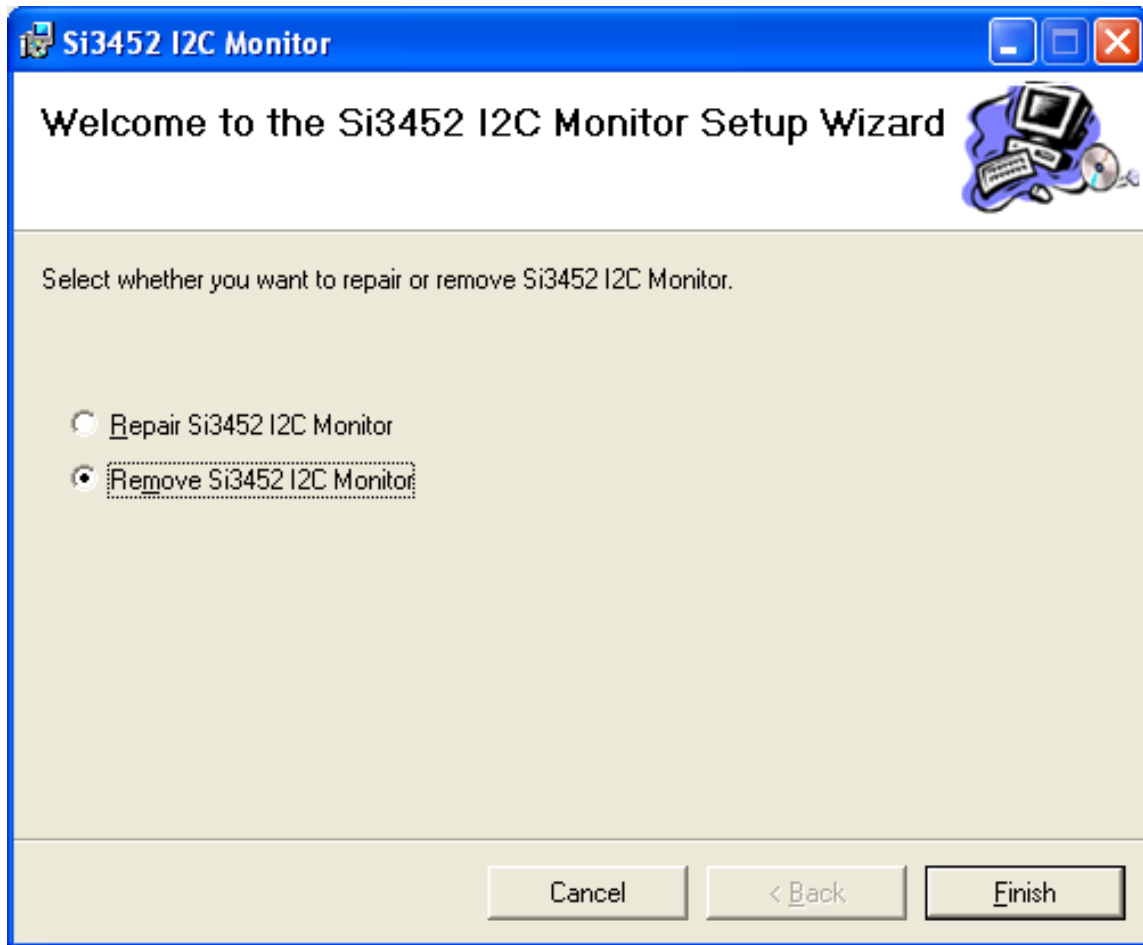

Figure 32. Monitor Setup Wizard

Si3452MS8-KIT

8. Ordering Guide

Due to the unique high-voltage and high-power design considerations, Silicon Labs recommends that the reference designs be followed closely. Visit the Silicon Labs Technical Support web page and register to submit a technical support request, particularly if you are not closely following the recommended reference design.

Ordering Part Number	Description
Si3452MS8-KIT	Evaluation board kit for Si3452, 8-port midspan evaluation board reference design. Populated with Si3452 devices. Refer to the Si3452 data sheet Ordering Guide section for current ordering and device configuration information.
Si3452-XYX-GM	Ordering part number for Si3452 devices. X = device revision; YY = firmware revision. Refer to the Si3452 data sheet Ordering Guide section for current ordering and device configuration information.

DOCUMENT CHANGE LIST

Revision 0.1 to Revision 0.2

- Updated Figures 13 and 14.
 - Added schematic notes
- Editorial changes related to layout guidelines.

Revision 0.2 to Revision 0.3

- Updated "2. Kit Contents" on page 2.
- Updated Table 1.

Revision 0.3 to Revision 0.4

- Updated kit contents in Table 1 on page 2.

Revision 0.4 to Revision 0.5

- Changed document title from Si3452MS8-EVB to Si3452MS8-KIT.
- Updated "3. Software Installation" on page 3.
- Updated "3.1. USB to I2C Driver Installation" on page 3.
- Updated "3.2. Si3452 Monitor GUI Installation" on page 5.
- Updated Figure 3 on page 5.
- Updated " Uninstalling the Si3452 Monitor GUI" on page 37.

Si3452MS8-KIT

CONTACT INFORMATION

Silicon Laboratories Inc.
400 West Cesar Chavez
Austin, TX 78701
Tel: 1+(512) 416-8500
Fax: 1+(512) 416-9669
Toll Free: 1+(877) 444-3032

Please visit the Silicon Labs Technical Support web page:
<https://www.silabs.com/support/pages/contacttechnicalsupport.aspx>
and register to submit a technical support request.

The information in this document is believed to be accurate in all respects at the time of publication but is subject to change without notice. Silicon Laboratories assumes no responsibility for errors and omissions, and disclaims responsibility for any consequences resulting from the use of information included herein. Additionally, Silicon Laboratories assumes no responsibility for the functioning of undescribed features or parameters. Silicon Laboratories reserves the right to make changes without further notice. Silicon Laboratories makes no warranty, representation or guarantee regarding the suitability of its products for any particular purpose, nor does Silicon Laboratories assume any liability arising out of the application or use of any product or circuit, and specifically disclaims any and all liability, including without limitation consequential or incidental damages. Silicon Laboratories products are not designed, intended, or authorized for use in applications intended to support or sustain life, or for any other application in which the failure of the Silicon Laboratories product could create a situation where personal injury or death may occur. Should Buyer purchase or use Silicon Laboratories products for any such unintended or unauthorized application, Buyer shall indemnify and hold Silicon Laboratories harmless against all claims and damages.

Silicon Laboratories and Silicon Labs are trademarks of Silicon Laboratories Inc.
Other products or brandnames mentioned herein are trademarks or registered trademarks of their respective holders.